

CMOS area image sensor

S15683-13



CMOS area image sensor for X-ray imaging (USB interface type)

The S15683-13 is a CMOS area image sensor developed for X-ray imaging. This image sensor has 2.14 mega pixels (1300 × 1700) with a pixel size of 20 × 20 μm and a monitoring photodiode for monitoring and detecting X-ray irradiation. FOP (fiber optic plate) used as the input window ensures high image quality and long sensor life even under exposure to X-rays. This image sensor is small and easy to incorporate into the equipment. The S15683-13 supports USB 2.0 and is designed to be dust and water proof, equivalent of IP67.

Features

- Pixel size: 20 × 20 μm
- 1300 (H) × 1700 (V) pixel format
- Total dose irradiation: 1000 kGy max.
- High resolution: 20 Lp/mm typ.
- Frame rate: 0.46 fps
- USB 2.0 interface
- Three sensors can be connected to one PC at a time.

Applications

- Non-destructive inspection
- General X-ray imaging

Structure

Parameter	Specification	Unit
Image size (H × V)	26 × 34	mm
Pixel size (H × V)	20 × 20	μm
Pixel pitch	20	μm
Number of total pixels (H × V)	1300 × 1706	pixels
Number of effective pixels (H × V)	1300 × 1700	pixels
Number of light-shielded pixels	Upper part: 756, 758, 760 Lower part: 1300 × 3	pixels
Scintillator type	CsI(Tl)	-
Interface	USB 2.0	-
Cable length	2.0	m

▣ Absolute maximum ratings (Ta=25 °C unless otherwise noted)

Parameter	Symbol	Condition	Min.	Typ.	Max.	Unit
Supply voltage	V _{bus}		4.75	5	5.25	V
Operating temperature	T _{opr}	No dew condensation*1	0	-	35	°C
Operating humidity	H _{opr}	No dew condensation*1	-	-	70	%
Operating pressure	P _{opr}		700	-	1060	hPa
Storage temperature	T _{stg}	No dew condensation*1	-20	-	70	°C
Storage humidity	H _{stg}	No dew condensation*1	-	-	70	%
Storage pressure	P _{stg}		700	-	1060	hPa
Tensile strength	TS	*2	-	-	100	N
X-ray tube voltage	Ex-ray		20	70	90	kV
Total dose irradiation	D	*3	-	-	1000	kGy

*1: When there is a temperature difference between a product and the surrounding area in high humidity environments, dew condensation may occur on the product surface. Dew condensation on the product may cause deterioration in characteristics and reliability.

*2: Connection between the CMOS sensor and the cable

*3: Tube voltage=60 kV, no Al added filter

Note: Exceeding the absolute maximum ratings even momentarily may cause a drop in product quality. Always be sure to use the product within the absolute maximum ratings.

▣ Electrical and optical characteristics (image sensor, Ta=25 °C, V_{bus}=5 V)

Parameter	Symbol	Min.	Typ.	Max.	Unit	
X-ray sensitivity*4	S _{x-ray}	13	19	25	LSB/μGy	
Saturation output	D _{sat}	3280	4900	-	LSB	
Saturation dose*4	L _{sat}	130	260	380	μGy	
X-ray response nonuniformity*4 *5 *6	XRNU	-	-	±30	%	
Dark output effective pixels*5	D _{dark}	-	350	900	LSB/s	
Readout noise	D _{Nread}	-	7	21	LSB rms	
Dynamic range*7	DR	44	57	-	dB	
X-ray resolution*4	RESO _{x-ray}	15	20	-	Lp/mm	
Contrast transfer function*8	CTF	0.15	0.23	-	-	
Blemish*4	Point defect*9	White spot	-	0	20	-
		Black spot	-	0	20	-
	Cluster defect*10	-	0	3	-	
	Column defect*11	-	0	0	-	
Defect line*4 *12	DL	-	0	1	lines	

*4: Tube voltage=70 kV, tube current=6 mA, SID (source to image-receptor distance)=510 mm, no Al added filter

*5: Average value excluding defective pixels

*6: XRNU (%)=(ΔS/S) × 100

S is the average value of an X-ray output signal.

ΔS is the difference between S and the maximum or the minimum value of X-ray output signals.

ΔS is calculated from an X-ray image corrected by dark subtraction excluding any defect.

XRNU specification is not applied to 5 pixels from the edge of effective pixels.

*7: DR=20 × log (D_{sat}/D_{Nread})

*8: 10 line pairs/mm

*9: White spot > 9000 LSB/s

Black spot > 50% reduction in response relative to adjacent pixels, measured at half of saturation output

*10: Continuous 2 to 9 point defects

*11: Continuous 10 or more point defects excluding a defect line

*12: A defect line consists of 10 or more point defects in 1 pixel width.

Electrical and optical characteristics (monitoring photodiode, Ta=25 °C, VBUS=5 V)

Parameter	Symbol	Min.	Typ.	Max.	Unit
X-ray sensitivity*13	S_MPD	-	63	-	LSB*14
Saturation output*15	Dsat_MPD	-	-	1023	LSB
A/D converter offset*16	Offset_MPD	426	432	438	LSB
Random noise*17	Nmd_MPD	0.1	0.4	1	LSB rms

*13: Tube voltage=70 kVp, tube current=6 mA, SID=510 mm, no Al added filter

*14: The unit means the output of the monitoring photodiode when the dose rate is 1 µGy/ms.

*15: The saturation value includes offset value.

*16: An A/D converter offset is a "mode" value of monitoring photodiode data without X-ray irradiation. "Mode" is a statistic term and the number that appears the most often in a set of numbers. This value is dependent on the PC and surrounding environment, and varies per sensor.

*17: Random noise is a standard deviation of a series of monitoring photodiode data without X-ray irradiation.

Electrical characteristics (Ta=25 °C, VBUS=5 V)

Parameter	Symbol	Min.	Typ.	Max.	Unit
Frame rate*18	FR	-	-	0.46	fps
Readout time	tread	-	2.2	-	s
Integration time	tint	0.001	-	10	s
Consumption current	Image sensor (readout mode)	-	140	180	mA
	Monitoring photodiode	-	115	155	

*18: The frame rate does not include an integration time and the time for displaying an image after readout.

Feature 01 Set-up example

Up to three sensors can be connected to one PC at a time.

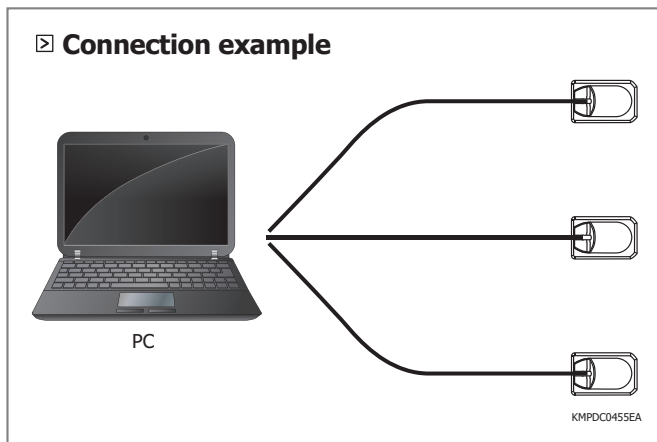

Feature 02 Monitoring photodiode

The monitoring photodiode is arranged along the entire circumference of the effective pixel area and this will monitor dose rates. When you get an image, if the output of the monitoring photodiode gets higher than a certain threshold, you can get an image automatically. You need to get the output of the monitoring photodiode in order to set an appropriate threshold. However, you cannot get the output of monitoring photodiode while you get an image. You can get the output of the monitoring photodiode by calling the function prepared in DLL. The function is described in the CD-ROM attached to the product.

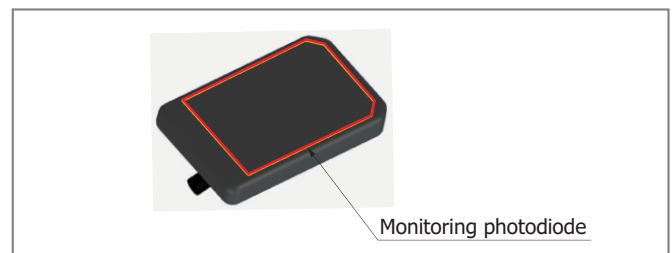

❑ MTF vs. spatial frequency*19 *20

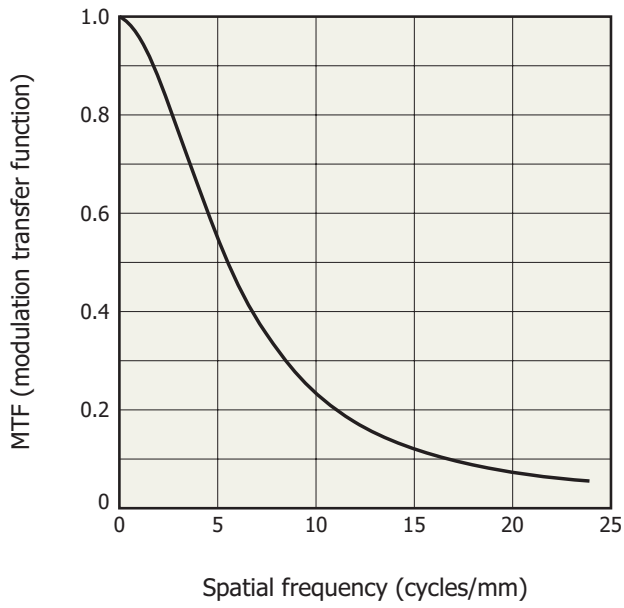

KMPDB0652EA

❑ DQE vs. spatial frequency*19 *20

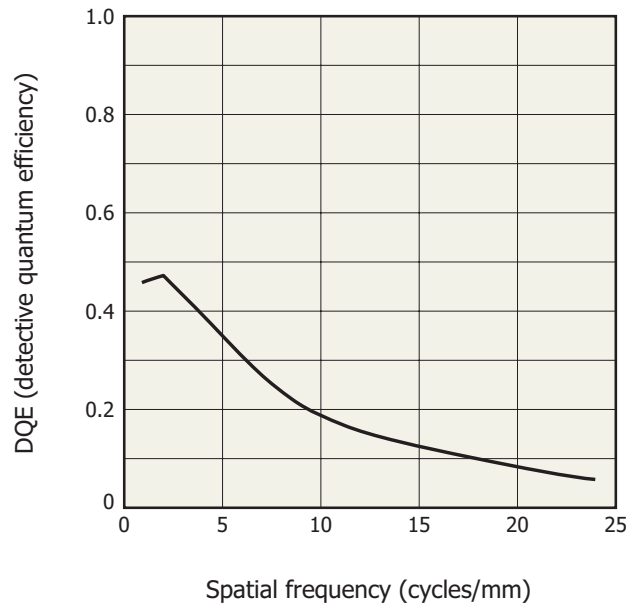

KMPDB0653EA

❑ Input/output characteristics*19

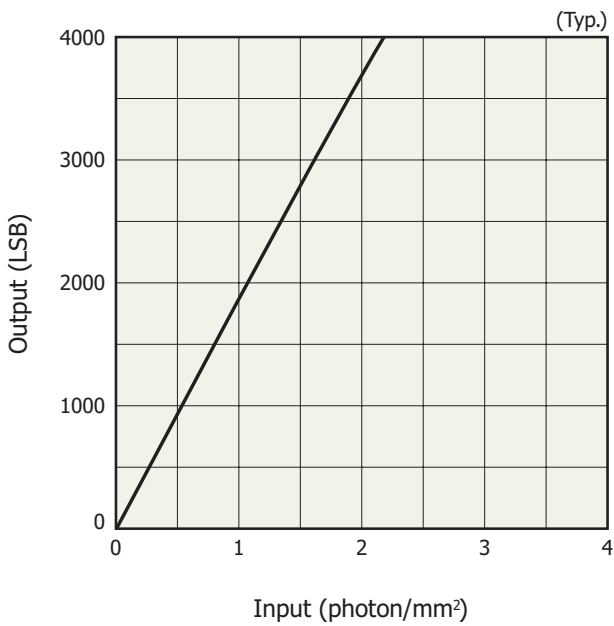

KMPDB0654EA

*19: X-ray radiation quality: RQA5
 Test condition: IEC 62220-1-1:2015
 *20: X-ray dose: 65 μGy

Acquired images of resolution chart

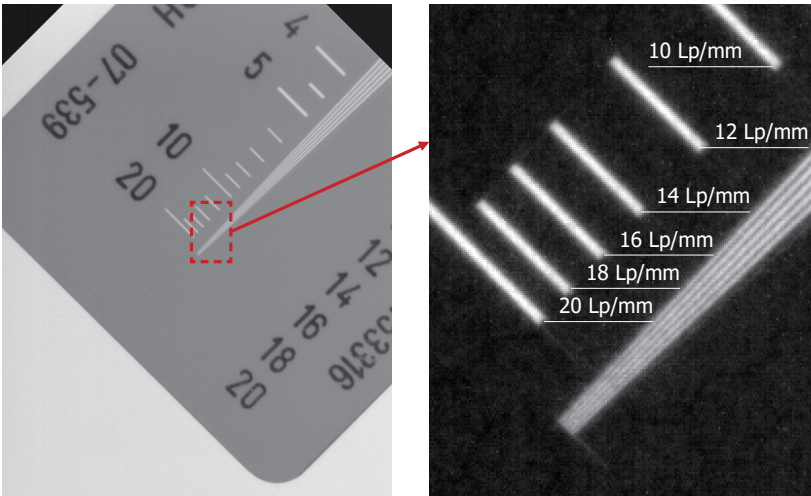

Three detection/integration modes

There are two ways to set an integration time. One is to be determined by the sensor automatically, and the other is to be determined by an operator. In addition, there are two different ways to start integration in the latter case. Totally, three acquisition modes are provided for the sensor as follow:

- Automatic detection / Automatic integration mode
When you are using DC type X-ray source, you will be able to take images automatically. AC type X-ray source is not suitable for this mode.
- Automatic detection / Manual integration mode
The start of integration is determined by the sensor automatically, but an integration time has to be set by an operator. When you are using AC type X-ray source, you will be able to take images properly. This mode will be available for both AC and DC type X-ray source.
- Manual detection / Manual integration mode
You will be able to take images without X-ray irradiation. Therefore, this mode is useful when you would like to take dark images as a background image. The integration time has to be set by an operator.

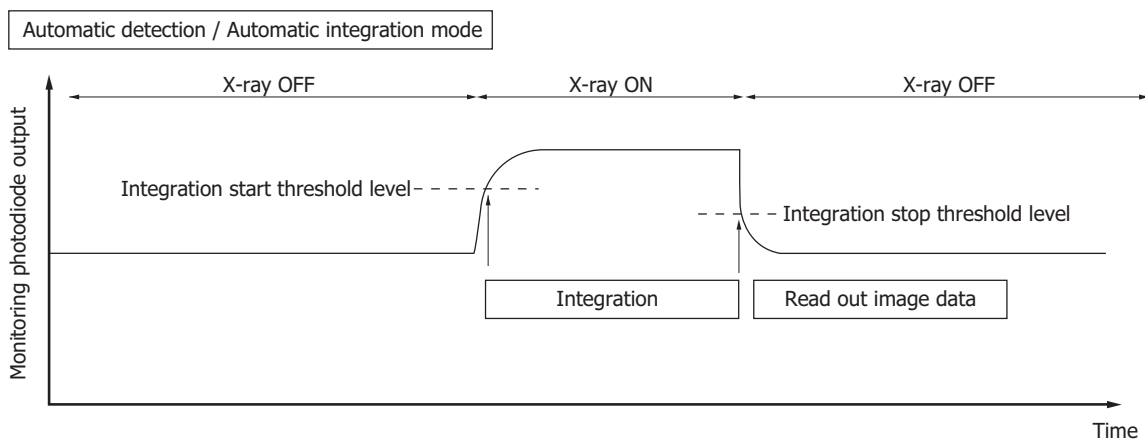

KMPDC0452EA

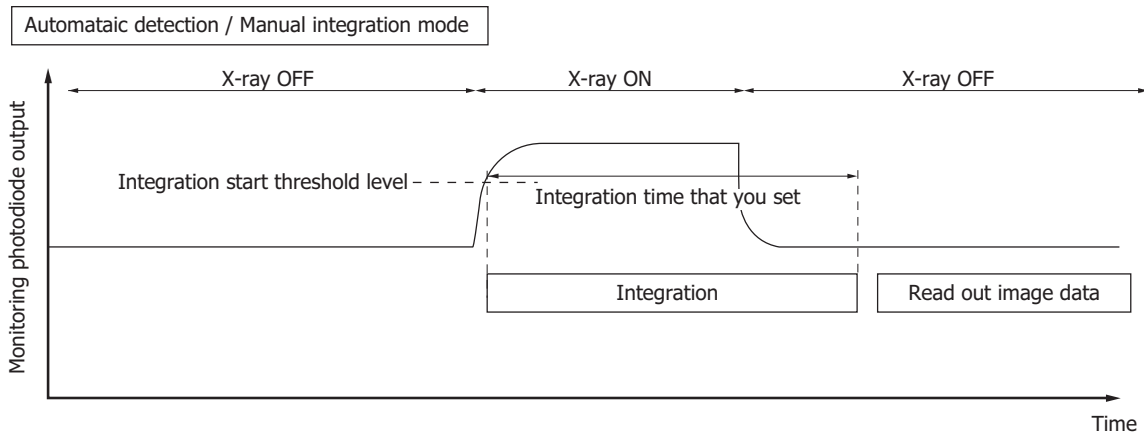

KMPDC0453EA

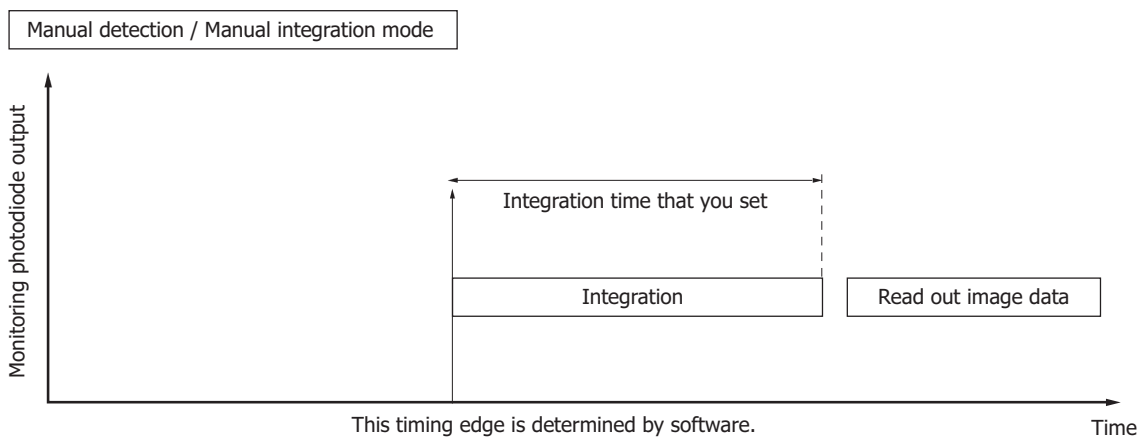

KMPDC0454EA

For details, please see a function manual attached to the CD-ROM.

Evaluation software*21

You can acquire and save images with attached evaluation software. The images are dark images, raw X-ray images, X-ray images subtracted by a dark image and X-ray images with flat-field correction. You can generate flat-fields for correcting the difference in sensitivity and use it on your application software.



*21: The evaluation software is not designed for medical use. You should use this software only for evaluating the sensor and must not use for medical use.

Dimensional outlines (unit: mm)

■ Entire view

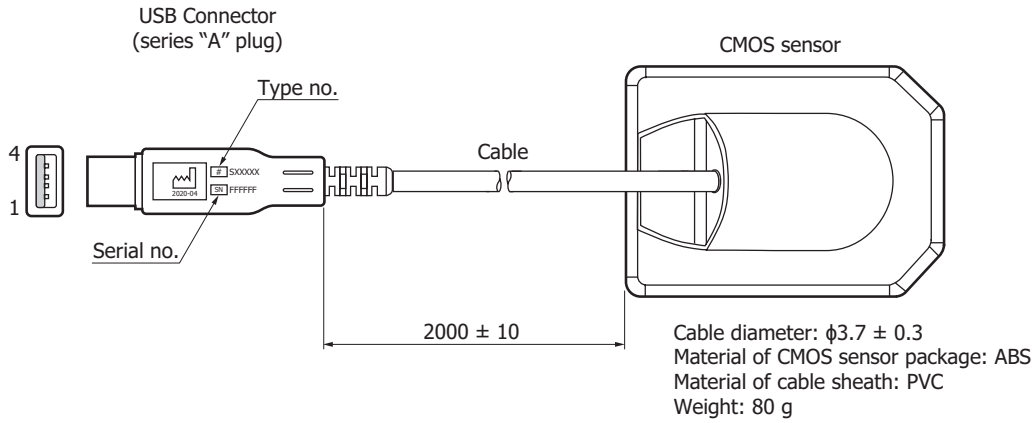

■ CMOS sensor

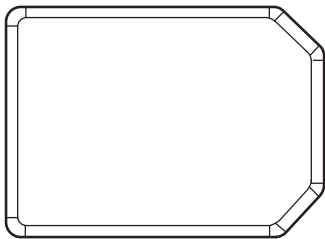
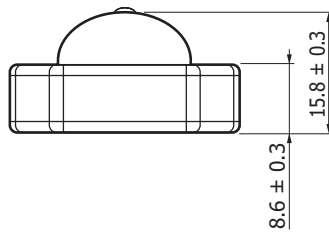
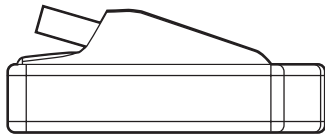
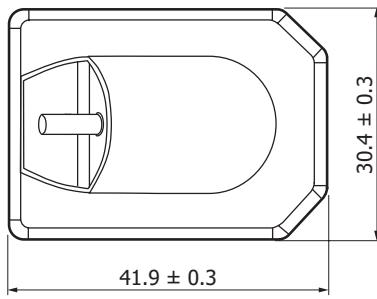

Standard packing:
 polypropylene box in moisture-proof bag
 [1 product/bag, bag size (W × H × D): 200 × 50 × 150
 gross weight: about 340 g]

KMPDA0630EC

■ Pin connections

Pin no.	Description
1	V _{BUS}
2	D-
3	D+
4	GND

Effective photosensitive area

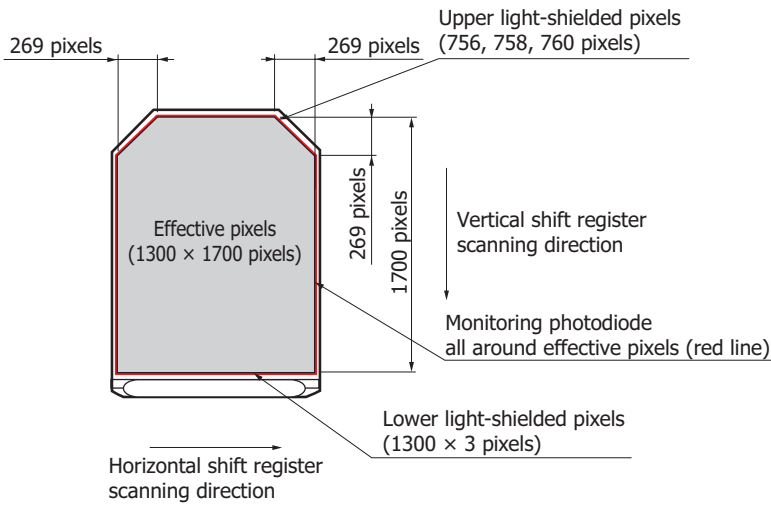

KMPDC0449EA

Labelings

- CD-ROM
(Evaluation software, USB driver, DLL, function manual)
- Documents (precautions for using image sensors, user's guide, final inspection sheet)

Recommended system requirements

Users must use Intel-based PCs.

- Windows
CPU: Intel core i5-2520M 2.5 GHz or higher
Memory: 4 GB or higher
Operating system: Microsoft® Windows® 7 SP1 32 and 64-bit
Microsoft Windows 8 64-bit
Microsoft Windows 8.1 64-bit
Microsoft Windows 10 64-bit
- Mac
CPU: Intel core i5 1.4 GHz or higher
Memory: 4 GB or higher
Operating system: macOS Sierra
macOS High Sierra
macOS Mojave

Note: Microsoft and Windows are either registered trademarks or trademarks of Microsoft Corporation in the United States and/or other countries.

Notice

This product is warranted for a period of 12 months after the date of the shipment. The warranty is limited to replacement or repair of any defective product due to defects in workmanship or materials used in manufacture. The warranty does not cover loss or damage caused by natural disaster, misuse (including modifications and any use not complying with the environment, application, usage and storage conditions described in this datasheet), or total radiation dose over 1000 kGy (tube voltage=60 kV) even within the warranty period.

Estimated useful life*22

5 years

(if you keep the product safely according to this datasheet)

*22: Estimated useful life does not mean a warranty period.

Related information

www.hamamatsu.com/sp/ssd/doc_en.html

Precautions

- Disclaimer

Information described in this material is current as of April 2021.

Product specifications are subject to change without prior notice due to improvements or other reasons. This document has been carefully prepared and the information contained is believed to be accurate. In rare cases, however, there may be inaccuracies such as text errors. Before using these products, always contact us for the delivery specification sheet to check the latest specifications.

The product warranty is valid for one year after delivery and is limited to product repair or replacement for defects discovered and reported to us within that one year period. However, even if within the warranty period we accept absolutely no liability for any loss caused by natural disasters or improper product use. Copying or reprinting the contents described in this material in whole or in part is prohibited without our prior permission.

HAMAMATSU

www.hamamatsu.com

HAMAMATSU PHOTONICS K.K., Solid State Division

1126-1 Ichino-cho, Higashi-ku, Hamamatsu City, 435-8558 Japan, Telephone: (81)53-434-3311, Fax: (81)53-434-5184

U.S.A.: Hamamatsu Corporation: 360 Foothill Road, Bridgewater, N.J. 08807, U.S.A., Telephone: (1)908-231-0960, Fax: (1)908-231-1218, E-mail: usa@hamamatsu.com

Germany: Hamamatsu Photonics Deutschland GmbH: Arzbergerstr. 10, D-82211 Herrsching am Ammersee, Germany, Telephone: (49)8152-375-0, Fax: (49)8152-265-8, E-mail: info@hamamatsu.de

France: Hamamatsu Photonics France S.A.R.L.: 19, Rue du Saule Trapu, Parc du Moulin de Massy, 91882 Massy Cedex, France, Telephone: (33)1 69 53 71 00, Fax: (33)1 69 53 71 10, E-mail: infos@hamamatsu.fr

United Kingdom: Hamamatsu Photonics UK Limited: 2 Howard Court, 10 Tewin Road, Welwyn Garden City, Hertfordshire AL7 1BW, UK, Telephone: (44)1707-294888, Fax: (44)1707-325777, E-mail: info@hamamatsu.co.uk

North Europe: Hamamatsu Photonics Norden AB: Torshamnsgatan 35 16440 Kista, Sweden, Telephone: (46)8-509 031 00, Fax: (46)8-509 031 01, E-mail: info@hamamatsu.se

Italy: Hamamatsu Photonics Italia S.r.l.: Strada della Moia, 1 int. 6, 20044 Arese (Milano), Italy, Telephone: (39)02-93 58 17 33, Fax: (39)02-93 58 17 41, E-mail: info@hamamatsu.it

China: Hamamatsu Photonics (China) Co., Ltd.: 1201 Tower B, Jiaming Center, 27 Dongsanhuan Beilu, Chaoyang District, 100020 Beijing, P.R.China, Telephone: (86)10-6586-6006, Fax: (86)10-6586-2866, E-mail: hpc@hamamatsu.com.cn

Taiwan: Hamamatsu Photonics Taiwan Co., Ltd.: 8F-3, No. 158, Section2, Gongdao 5th Road, East District, Hsinchu, 300, Taiwan R.O.C. Telephone: (886)3-659-0080, Fax: (886)3-659-0081, E-mail: info@hamamatsu.com.tw