

TOSHIBA CCD Linear Image Sensor CCD (charge coupled device)

# TCD2561D

The TCD2561D is a high sensitive and low dark current 5340 elements × 4 line CCD color image sensor which includes CCD drive circuit, clamp circuit.

The sensor is designed for scanner. The device contains a row of 5340 elements × 4 line photodiodes which provide a 24 lines/mm across a A4 size paper. The device is operated by 5 V pulse and 12 V power supply.

## Features

- Number of image sensing elements: 5340 elements × 4 line
- Image sensing element size: 7 μm × 7 μm on 7 μm centers
- Photo sensing region: High sensitive PN photodiode
- Distanced between photodiode array: Color (28 μm, 4 lines), B/W-color (56 μm, 8 lines)
- Clock: 2 phase (5 V)
- Power supply: 12 V power supply voltage
- Internal circuit: Clamp circuit
- Package: 22 Pin CERDIP package
- Color filter: Red, green, blue

## Maximum Ratings (Note1)

Characteristic	Symbol	Rating	Unit
Clock pulse voltage	$V_{\phi}$	-0.3~8.0	V
Shift pulse voltage	$V_{SH}$		V
Reset pulse voltage	$V_{\overline{RS}}$		V
Clamp pulse voltage	$V_{\overline{CP}}$		V
Changeover switch voltage	$V_{\overline{SW}}$		V
Power supply voltage	$V_{OD}$	-0.3~15	V
Operating temperature	$T_{opr}$	0~60	°C
Storage temperature	$T_{stg}$	-25~85	°C

Note 1: All voltage are with respect to SS terminals (ground).

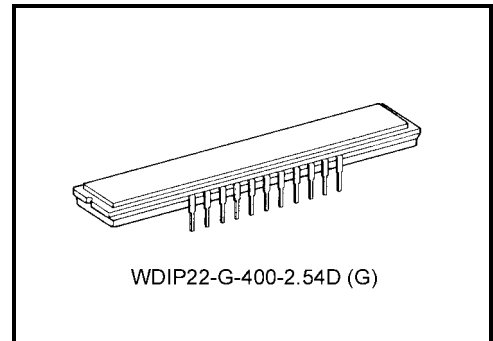

Weight: 5.2 g (typ.)

## Pin Connections (top view)

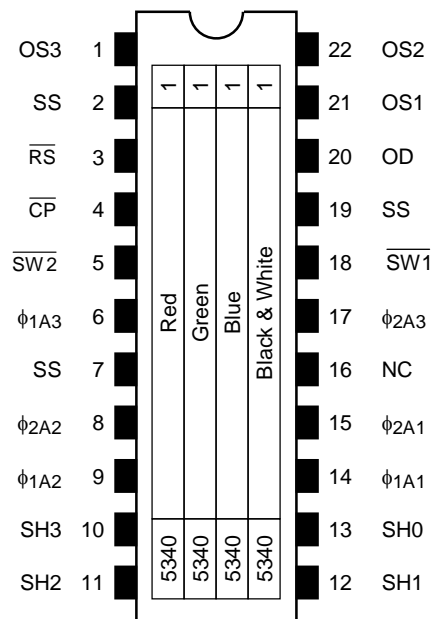

## Circuit Diagram

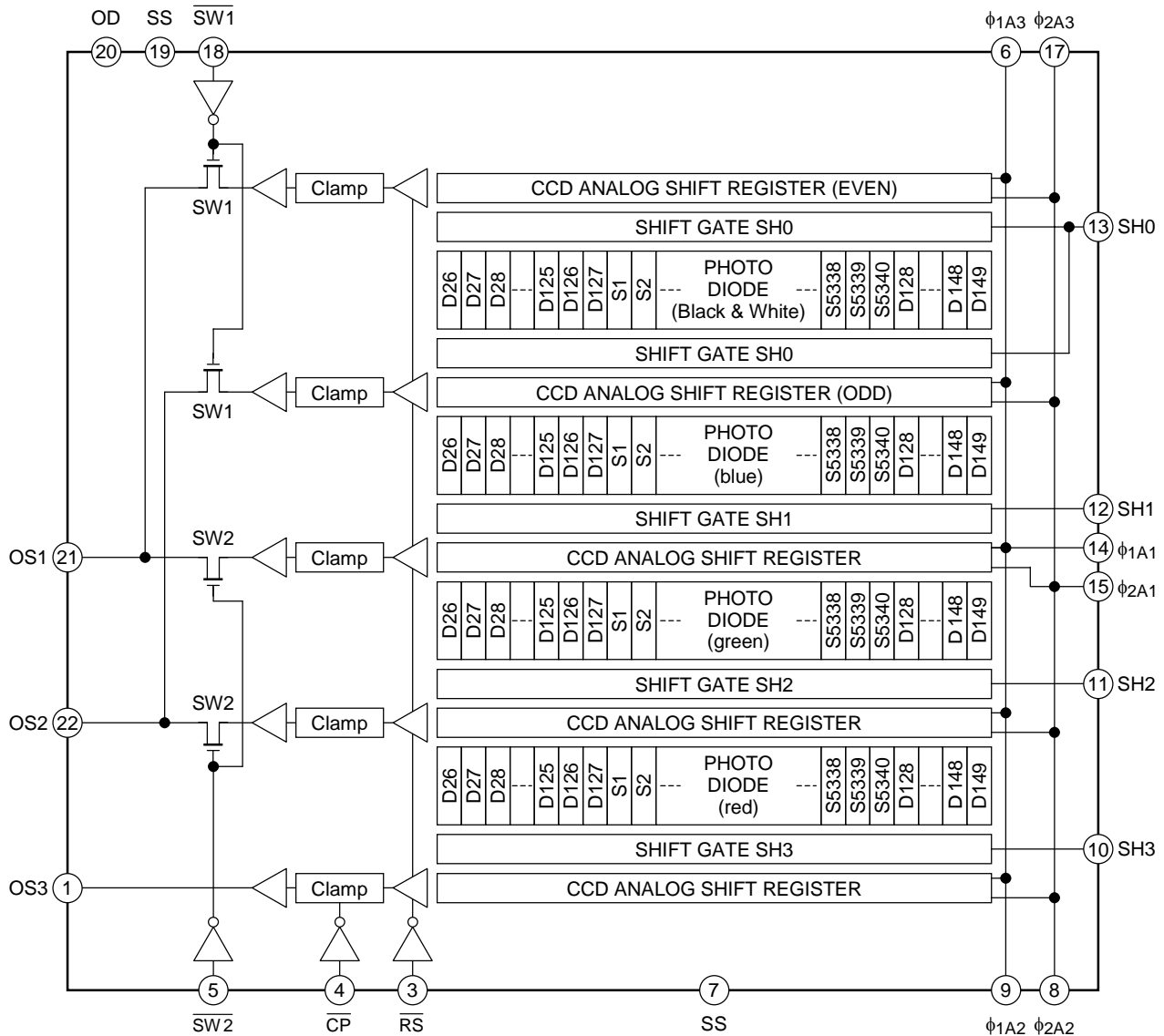

## Pin Names

OS3	Signal Output 3 (red)	OS2	Signal Output 2 (green)
SS	Ground	OS1	Signal Output 1 (blue)
$\overline{RS}$	Reset Gate	OD	Power
$\overline{CP}$	Clamp Gate	SS	Ground
$\overline{SW2}$	Changeover Switch 2 (color and B/W)	$\overline{SW1}$	Changeover Switch 1 (color and B/W)
$\phi_{1A3}$	Clock 3 (phase 1)	$\phi_{2A3}$	Clock 3 (phase 2)
SS	Ground	NC	Non Connection
$\phi_{2A2}$	Clock 2 (phase 2)	$\phi_{2A1}$	Clock 1 (phase 2)
$\phi_{1A2}$	Clock 2 (phase 1)	$\phi_{1A1}$	Clock 1 (phase 1)
SH3	Shift Gate 3	SH0	Shift Gate 0
SH2	Shift Gate 2	SH1	Shift Gate 1

## Optical/Electrical Characteristics

( $T_a = 25^\circ\text{C}$ ,  $V_{OD} = 12\text{ V}$ ,  $V_\phi = V_{RS} = V_{SH} = V_{CP} = 5\text{ V (pulse)}$ ,  $f_\phi = 1.0\text{ MHz}$ ,  $f_{RS} = 1.0\text{ MHz}$ ,  
**LOAD RESISTANCE = 100 k $\Omega$** ,  **$t_{INT}$  (INTEGRATION TIME) = 10 ms**,  
**LIGHT SOURCE = A LIGHT SOURCE + CM500S FILTER ( $t = 1.0\text{ mm}$ )**)

Characteristics	Symbol	Min	Typ.	Max	Unit	Note
Sensitivity	$R_{B/W}$	16.8	21.0	25.2	V/(lx·s)	(Note 2)
	$R_R$	6.3	9.0	11.7		
	$R_G$	7.3	10.5	13.7		
	$R_B$	3.8	5.5	7.2		
Photo response non uniformity	PRNU (1)	—	10	20	%	(Note 3)
	PRNU (3)	—	3	12	mV	(Note 4)
Image lag	IL	—	1	—	%	(Note 5)
Saturation output voltage (B/W)	$V_{SAT (B/W)}$	1.5	2.0	—	V	(Note 6)
Saturation output voltage (color)	$V_{SAT (color)}$	3.2	3.5	—	V	(Note 6)
Saturation exposure	SE	—	0.1	—	lx·s	(Note 7)
Dark signal voltage	$V_{DRK}$	—	0.4	2.0	mV	(Note 8)
Dark signal non uniformity	DSNU	—	7	12	mV	(Note 8)
DC power dissipation	$P_D$	—	480	690	mW	—
Total transfer efficiency	TTE	92	—	—	%	—
Output impedance	$Z_O$	—	0.3	1.0	k $\Omega$	—
DC signal output voltage	$V_{OS}$	5.0	6.0	7.0	V	(Note 9)
Random noise	$N_{D\sigma}$	—	1.0	—	mV	(Note 10)
Reset noise	$V_{RSN}$	—	0.5	1.0	V	(Note 9)

Note 2: Sensitivity is defined for each color of signal outputs average when the photosensitive surface is applied with the light of uniform illumination and uniform color temperature.

Note 3: PRNU (1) is defined for each color on a single chip by the expressions below when the photosensitive surface is applied with the light of uniform illumination and uniform color temperature.

$$\text{PRNU (1)} = \frac{\Delta X}{\bar{X}} \times 100 (\%)$$

When  $\bar{X}$  is average of total signal output and  $\Delta X$  is the maximum deviation from  $\bar{X}$ . The amount of incident light is shown below.

$$\text{Red} = \frac{1}{2} \text{ SE}, \text{ Green} = \frac{1}{2} \text{ SE}, \text{ Blue} = \frac{1}{4} \text{ SE}$$

Note 4: PRNU (3) is defined as maximum voltage with next pixel, where measured 5% of SE (typ.)

Note 5: Image Lag is defined as follows.

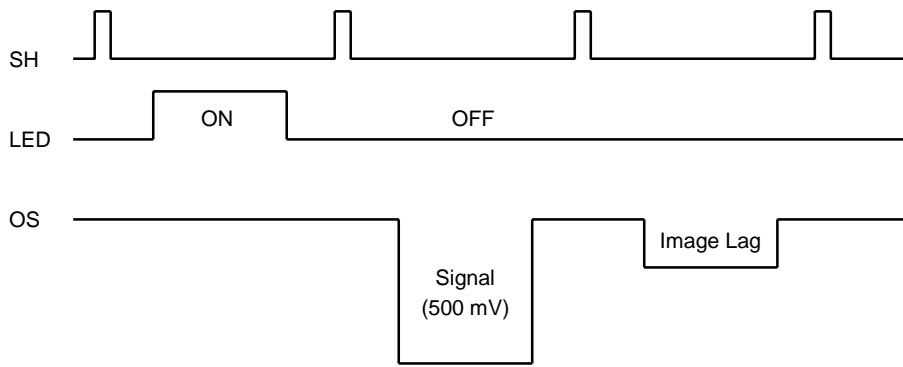

Note 6:  $V_{SAT}$  is defined as minimum saturation output of all effective pixels.

Note 7: Definition of SE:  $SE = \frac{V_{SAT}}{R_{B/W}} (lx \cdot s)$

Note 8:  $V_{DRK}$  is defined as average dark signal voltage of all effective pixels. DSNU is defined as different voltage between  $V_{DRK}$  and  $V_{MDK}$  when  $V_{MDK}$  is maximum dark signal voltage.

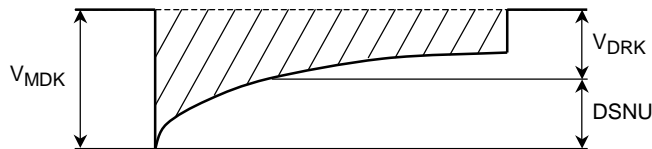

Note 9: DC signal Output Voltage and Reset Noise is defined as follows, but Reset Noise is a fixed pattern noise.

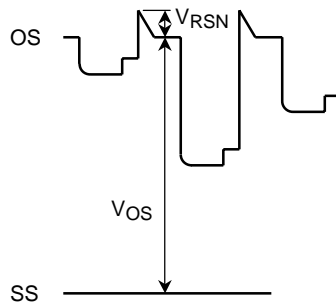

Note 10: Random noise is defined as the standard deviation (sigma) of the output level difference between two adjacent effective pixels under no illumination (i.e. dark conditions) calculated by the following procedure.

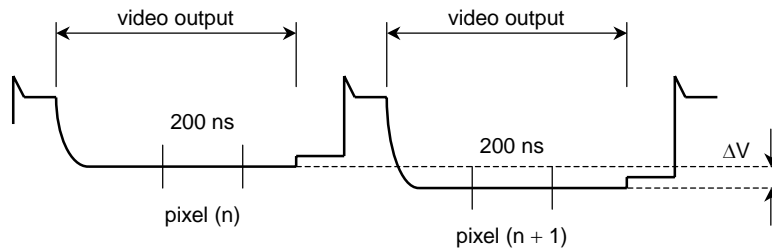

Output waveform (effective pixels under dark condition)

- (1) Two adjacent pixels (pixel n and n + 1) in one reading are fixed as measurement points.
- (2) Each of the output level at video output periods averaged over 200 ns period to get V (n) and V (n + 1).
- (3) V (n + 1) is subtracted from V (n) to get ΔV.  

$$\Delta V = V(n) - V(n + 1)$$
- (4) The standard deviation of ΔV is calculated after procedure (2) and (3) are repeated 30 times (30 readings)

$$\overline{\Delta V} = \frac{1}{30} \sum_{i=1}^{30} |\Delta V_i| \qquad \sigma = \sqrt{\frac{1}{30} \sum_{i=1}^{30} (|\Delta V_i| - \overline{\Delta V})^2}$$

- (5) Procedure (2), (3) and (4) are repeated 10 times to get sigma value.
- (6) 10 sigma values are averaged.

$$\overline{\sigma} = \frac{1}{10} \sum_{j=1}^{10} \sigma_j$$

- (7)  $\overline{\sigma}$  value calculated using the above procedure is observed  $\sqrt{2}$  times larger than that measured relative to the ground level. So we specify random noise as follows.

$$N_{D\sigma} = \frac{1}{\sqrt{2}} \overline{\sigma}$$

## Operating Condition

Characteristics		Symbol	Min	Typ.	Max	Unit	Note
Clock pulse voltage	"H" Level	$V_{\phi A}$	4.5	5.0	5.5	V	
	"L" Level		0	—	0.5		
Shift pulse voltage	"H" Level	$V_{SH}$	4.5	5.0	5.5	V	
	"L" Level		0	—	0.5		
Reset pulse voltage	"H" Level	$\overline{V_{RS}}$	4.5	5.0	5.5	V	
	"L" Level		0	—	0.5		
Clamp pulse voltage	"H" Level	$V_{\overline{CP}}$	4.5	5.0	5.5	V	
	"L" Level		0	—	0.5		
Switch pulse voltage	"H" Level	$V_{\overline{SW}}$	4.5	5.0	5.5	V	
	"L" Level		0	—	0.5		
Power supply voltage		$V_{OD}$	11.4	12.0	13.0	V	

## Clock Characteristics (Ta = 25°C)

Characteristics	Symbol	Min	Typ.	Max	Unit
Clock pulse frequency	$f_{\phi}$	0.3	1.0	10	MHz
Reset pulse frequency	$f_{\overline{RS}}$	0.3	1.0	10	MHz
Clamp pulse frequency	$f_{\overline{CP}}$	0.3	1.0	10	MHz
Clock1 capacitance (Note 11)	$C_{\phi 1}$	—	160	240	pF
Clock2 capacitance (Note 11)	$C_{\phi 2}$	—	130	195	pF
Shift gate capacitance	$C_{SH}$	—	30	60	pF
Reset gate capacitance	$C_{\overline{RS}}$	—	10	40	pF
Clamp gate capacitance	$C_{\overline{CP}}$	—	10	40	pF
Switch gate capacitance	$C_{\overline{SW}}$	—	10	40	pF

Note 11:  $V_{OD} = 12\text{ V}$

Timing Chart 1: Bit Clamp Mode (color or B/W mode)

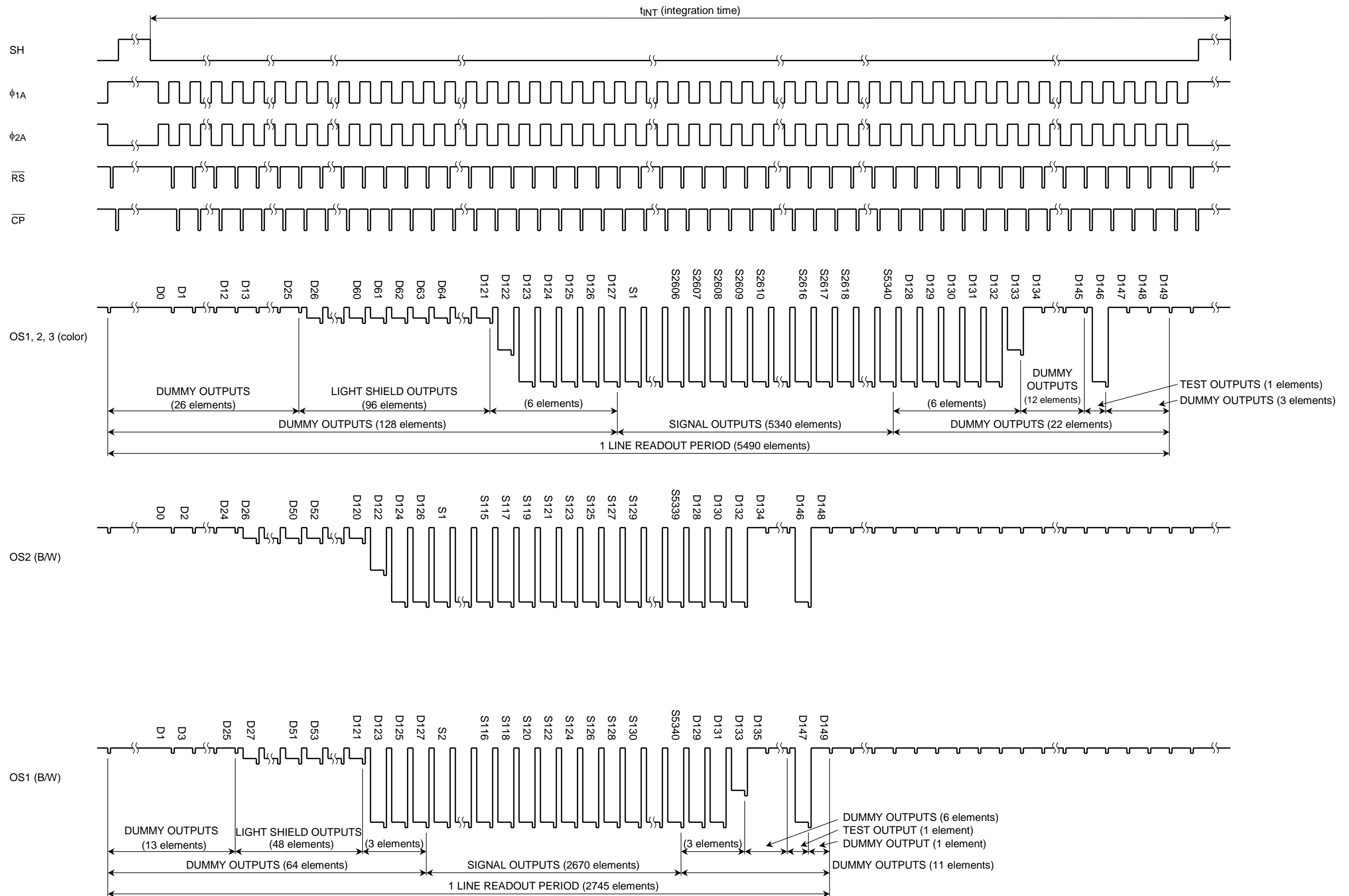

Timing Chart 2: Line Clamp Mode (color or B/W mode)

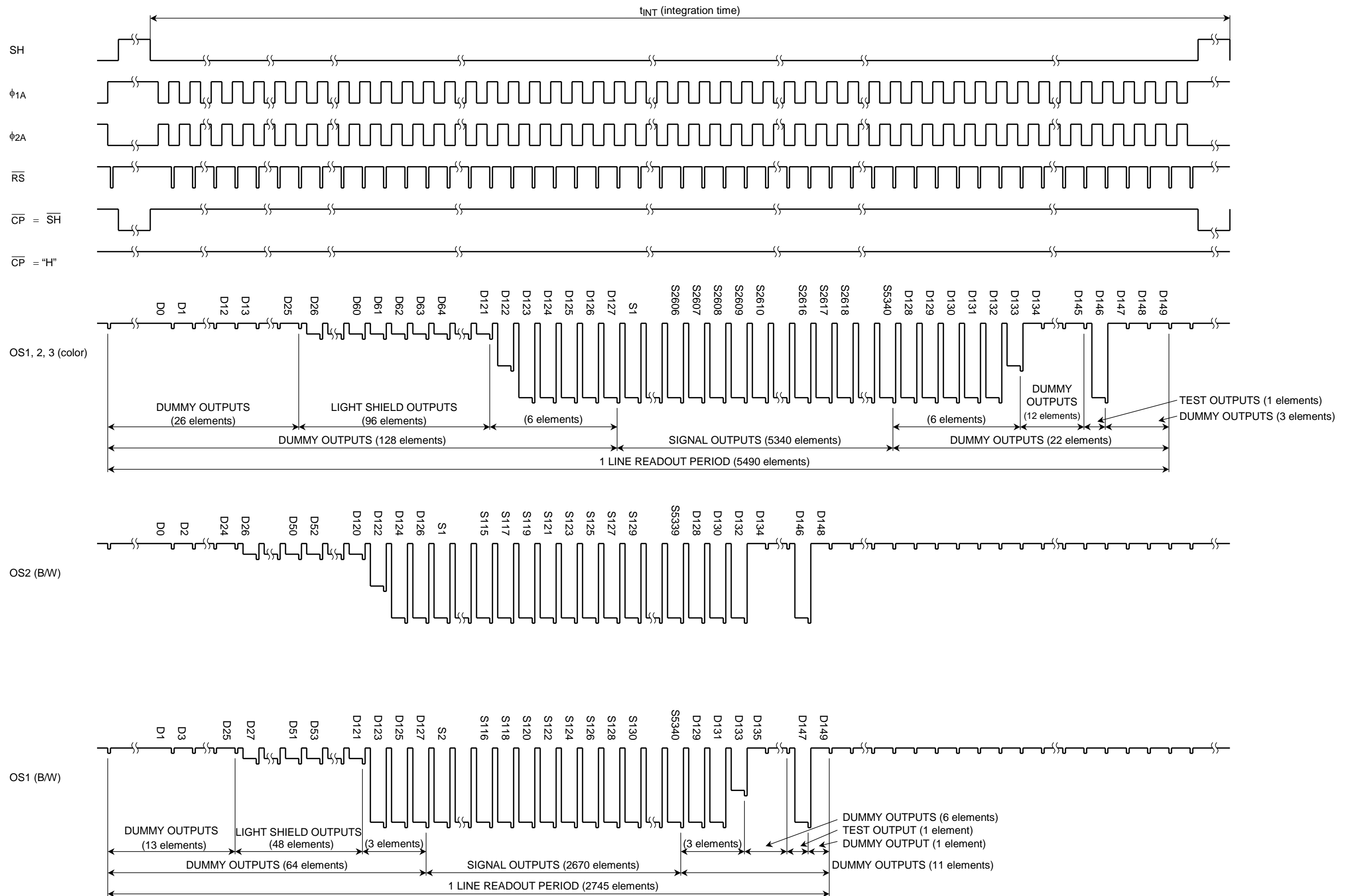



Timing Chart 3 (color → B/W mode)

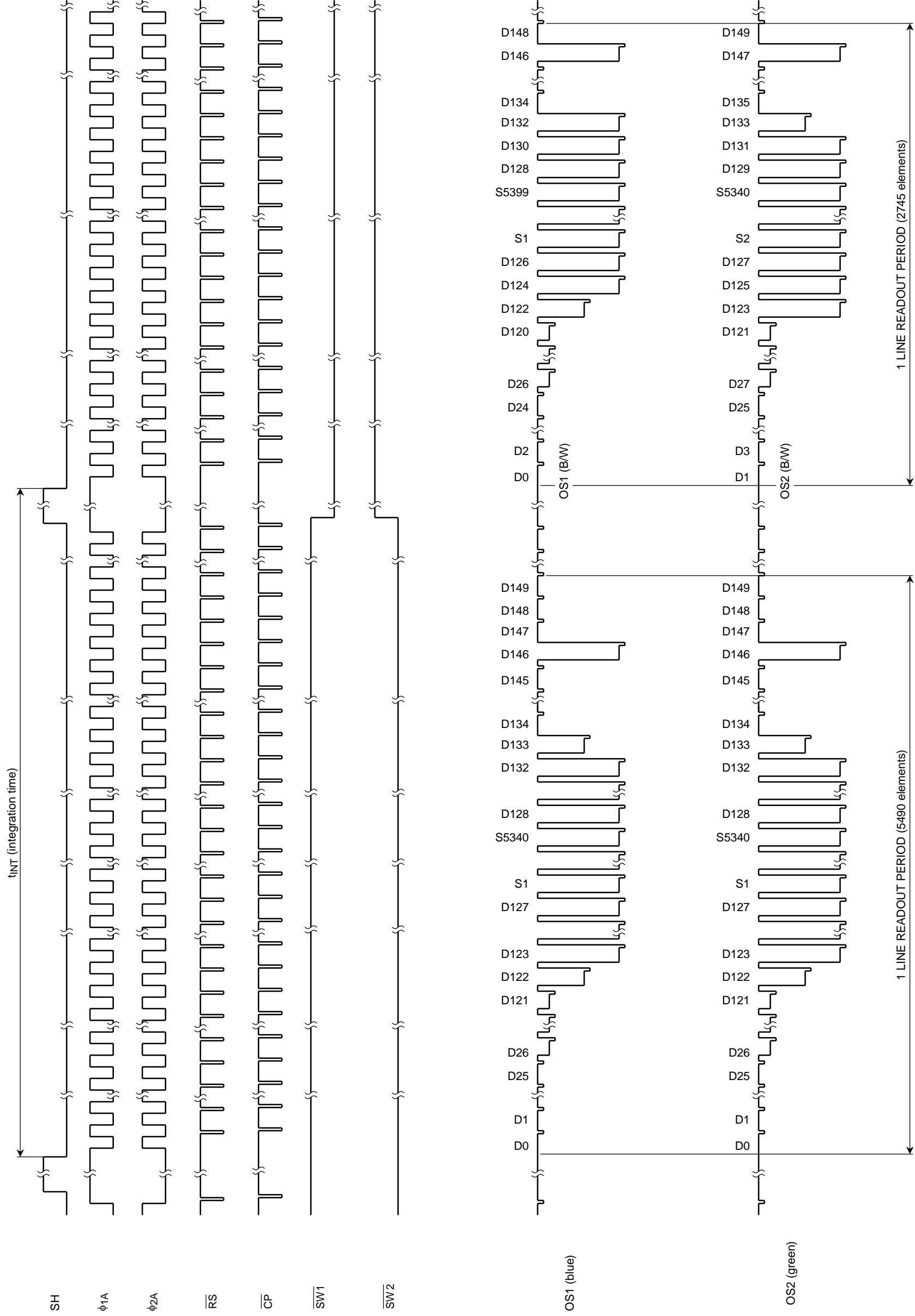

**Timing Requirements**

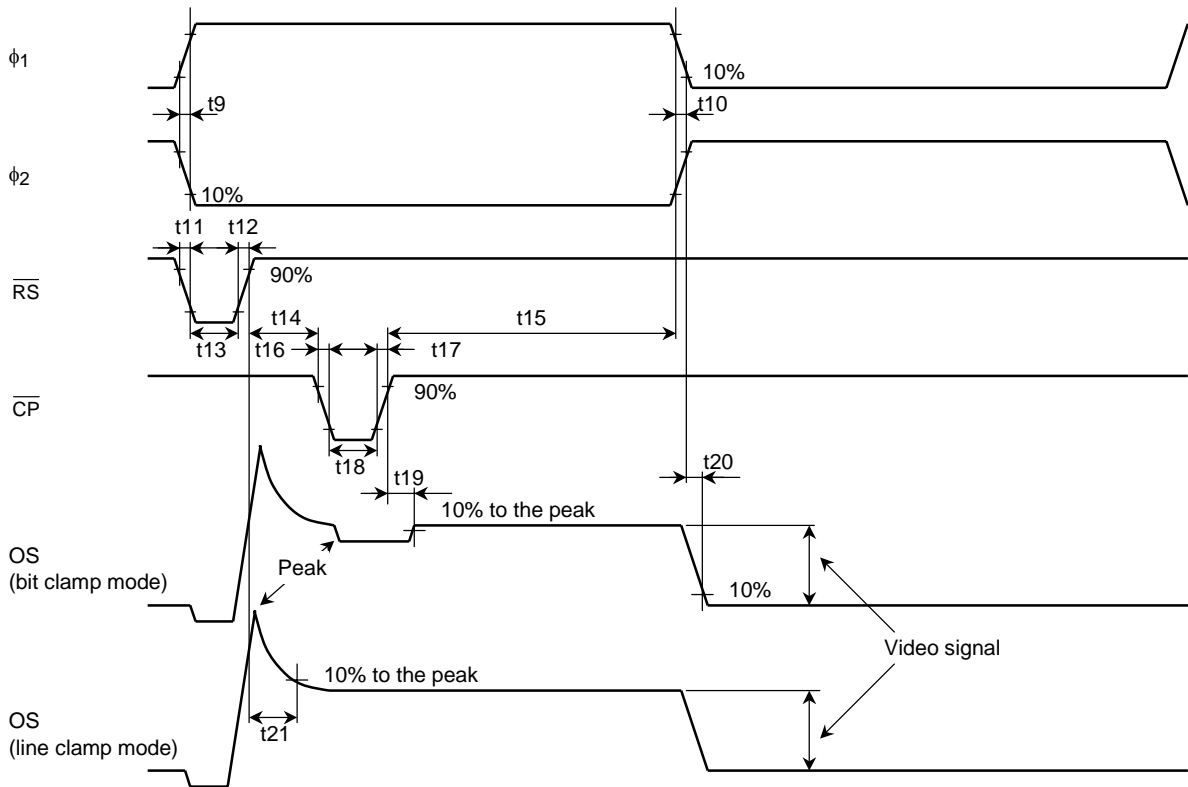
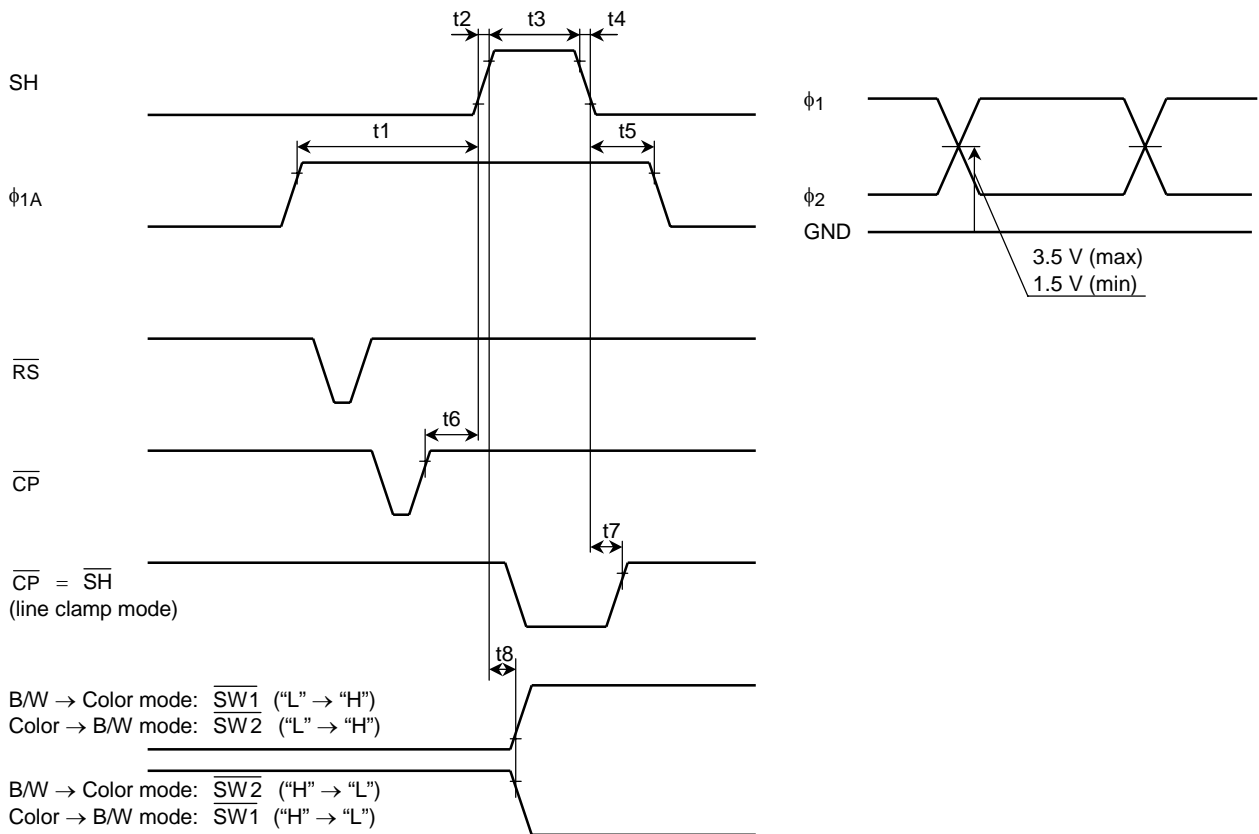

**Timing Requirements (cont.)**

Characteristics	Symbol	Min	Typ. (Note 12)	Max	Unit
Pulse timing of SH and $\phi 1$	t1	120	1000	—	ns
	t5	800	1000	—	
SH pulse rise time, fall time	t2, t4	0	50	—	ns
SH pulse width	t3	3000	5000	—	ns
Pulse timing of SH and $\overline{CP}$	t6	200	500	—	ns
Pulse timing of SH and $\overline{CP}$ (line clamp mode)	t7	10	100	—	ns
Pulse timing of SH and SW	t8	100	500	t3 – 100	ns
$\phi 1, \phi 2$ pulse rise time, fall time	t9, t10	0	50	—	ns
$\overline{RS}$ pulse rise time, fall time	t11, t12	0	20	—	ns
$\overline{RS}$ pulse width	t13	10 (20)	80	—	ns
Pulse timing of $\overline{RS}$ and $\overline{CP}$	t14	0	40	—	ns
Pulse timing of $\phi 1A, \phi 2A$ and $\overline{CP}$	t15	0	20	—	ns
$\overline{CP}$ pulse rise time, fall time	t16, t17	0	20	—	ns
$\overline{CP}$ pulse width (Note 13)	t18	30 (3000)	80 (5000)	—	ns
Reference level settle time (bit clamp mode)	t19	—	20	40 (Note 16)	ns
Video data delay time (Note 14)	t20	—	20	40 (Note 15)	ns
Reference level settle time (line clamp mode)	t21	—	30	50 (Note 16)	ns

Note 12: Typ. is the case of  $f_{\overline{RS}} = 1.0$  MHz.

Note 13: Line clamp Mode inside ( ).

Note 14: Load Resistance is 100 k $\Omega$ .

Note 15: Typical settle time to about 1% of final value.

Note 16: Typical settle time to about 1% of the peak.

**Clamp Mode**

Clamp Means	$\overline{CP}$ Input Pulse
Bit Clamp	$\overline{CP}$ Pulse
Line Clamp	“H” or $\overline{SH}$

**Changeover Switch Mode**

Output Type	$\overline{SW1}$ Input Pulse	$\overline{SW2}$ Input Pulse
Color	“H”	“L”
B/W	“L”	“H”

Typical Spectral Response

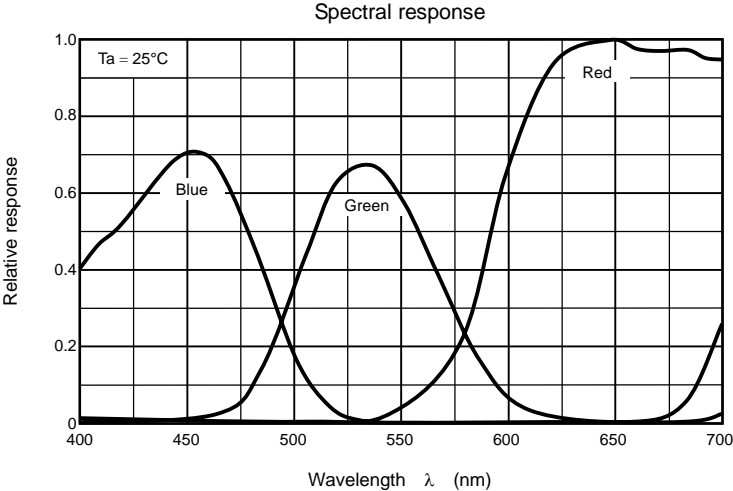

## Typical Drive Circuit

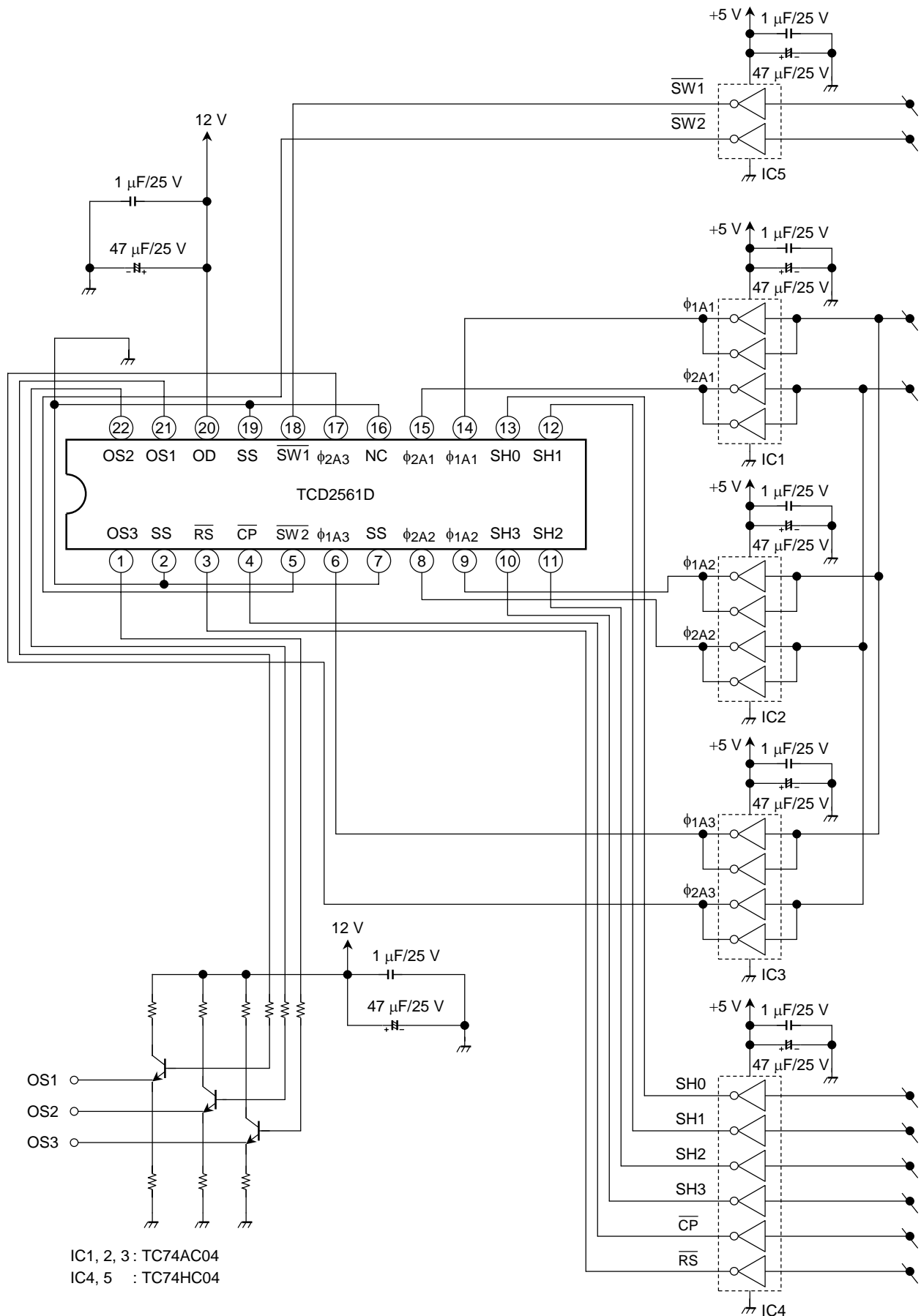

**Caution****1. Window Glass**

The dust and stain on the glass window of the package degrade optical performance of CCD sensor.

Keep the glass window clean by saturating a cotton swab in alcohol and lightly wiping the surface, and allow the glass to dry, by blowing with filtered dry N<sub>2</sub>. Care should be taken to avoid mechanical or thermal shock because the glass window is easily to damage.

**2. Electrostatic Breakdown**

Store in shorting clip or in conductive foam to avoid electrostatic breakdown.

CCD Image Sensor is protected against static electricity, but interior puncture mode device due to static electricity is sometimes detected. In handing the device, it is necessary to execute the following static electricity preventive measures, in order to prevent the trouble rate increase of the manufacturing system due to static electricity.

- a. Prevent the generation of static electricity due to friction by making the work with bare hands or by putting on cotton gloves and non-charging working clothes.
- b. Discharge the static electricity by providing earth plate or earth wire on the floor, door or stand of the work room.
- c. Ground the tools such as soldering iron, radio cutting pliers or pincer.

It is not necessarily required to execute all precaution items for static electricity.

It is all right to mitigate the precautions by confirming that the trouble rate within the prescribed range.

**3. Incident Light**

CCD sensor is sensitive to infrared light. Note that infrared light component degrades resolution and PRNU of CCD sensor.

**4. Lead Frame Forming**

Since this package is not strong against mechanical stress, you should not reform the lead frame.

We recommend to use a IC-inserter when you assemble to PCB.

**5. Soldering**

Soldering by the solder flow method cannot be guaranteed because this method may have deleterious effects on prevention of window glass soiling and heat resistance.

Using a soldering iron, complete soldering within ten seconds for lead temperatures of up to 260°C, or within three seconds for lead temperatures of up to 350°C.

**Package Dimensions**

WDIP22-G-400-2.54D (G)

Unit: mm

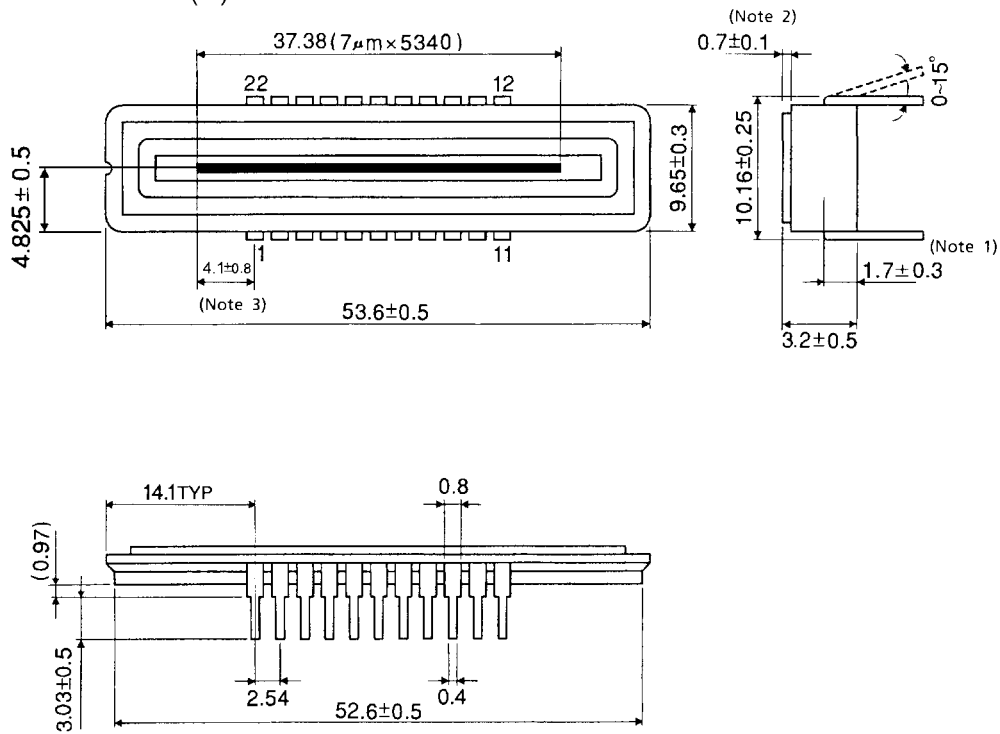

(Note 1) : TOP OF CHIP TO BOTTOM OF PACKAGE.

(Note 2) : GLASS THICKNESS (n = 1.5)

(Note 3) : No.1 SENSOR ELEMENT (S1) TO EDGE OF No.1 PIN.

Weight: 5.2 g (typ.)

**RESTRICTIONS ON PRODUCT USE**

000707EBA

- TOSHIBA is continually working to improve the quality and reliability of its products. Nevertheless, semiconductor devices in general can malfunction or fail due to their inherent electrical sensitivity and vulnerability to physical stress. It is the responsibility of the buyer, when utilizing TOSHIBA products, to comply with the standards of safety in making a safe design for the entire system, and to avoid situations in which a malfunction or failure of such TOSHIBA products could cause loss of human life, bodily injury or damage to property.  
In developing your designs, please ensure that TOSHIBA products are used within specified operating ranges as set forth in the most recent TOSHIBA products specifications. Also, please keep in mind the precautions and conditions set forth in the "Handling Guide for Semiconductor Devices," or "TOSHIBA Semiconductor Reliability Handbook" etc..
- The TOSHIBA products listed in this document are intended for usage in general electronics applications (computer, personal equipment, office equipment, measuring equipment, industrial robotics, domestic appliances, etc.). These TOSHIBA products are neither intended nor warranted for usage in equipment that requires extraordinarily high quality and/or reliability or a malfunction or failure of which may cause loss of human life or bodily injury ("Unintended Usage"). Unintended Usage include atomic energy control instruments, airplane or spaceship instruments, transportation instruments, traffic signal instruments, combustion control instruments, medical instruments, all types of safety devices, etc.. Unintended Usage of TOSHIBA products listed in this document shall be made at the customer's own risk.
- The products described in this document are subject to the foreign exchange and foreign trade laws.
- The information contained herein is presented only as a guide for the applications of our products. No responsibility is assumed by TOSHIBA CORPORATION for any infringements of intellectual property or other rights of the third parties which may result from its use. No license is granted by implication or otherwise under any intellectual property or other rights of TOSHIBA CORPORATION or others.
- The information contained herein is subject to change without notice.