

S9132

High-speed frame rate sensor capable of acquiring two-dimensional projection data

The profile sensor S9132 is a high-performance CMOS area sensor particularly intended to acquire projection data. A projection profile in the X and Y directions has very small amounts of data compared to normal area sensors and therefore allows high-speed position detection and moving object detection. The S9132 also has advantages over conventional 2D PSDs (Position Sensitive Detectors) that the output linearity is improved, multiple light spots can be detected and external circuits are simplified. A timing generator, bias voltage generator and 10-bit AD converter circuits are all integrated on the same chip, allowing operations with a very simple external driver circuit and external signal processing circuit.

Features

- Sensor for acquiring 2D projection data
- High-speed frame rate: 3200 frames/s max. (8-bit)
1600 frames/s max. (10-bit)
- Low power consumption
- Digital video output
- 10-bit/8-bit switchable ADC

Applications

- Light spot position detection (printers, FA inspection equipment, amusement machines)
- Moving object detection (FA inspection equipment, amusement machines)
- 3D measurement (FA inspection equipment, medical measurement)

Conceptual view of light spot detection

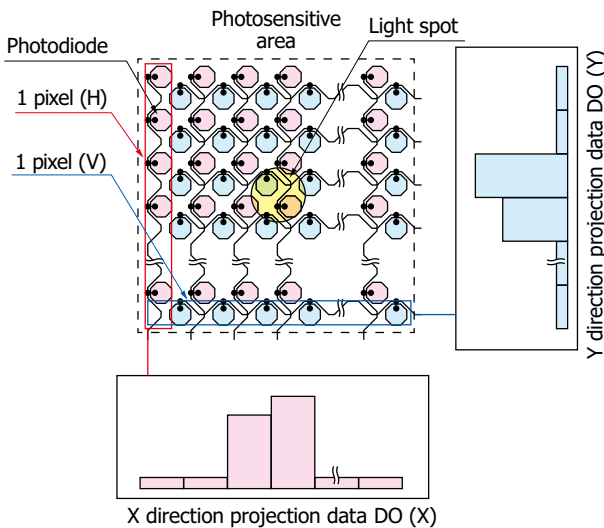

KMPDC1038EA

Structure

Parameter	Specification	Unit
Number of pixels	256 (H) + 256 (V)	-
Pixel pitch	7.8	μm
Pixel size	7.8 × 1996.8	μm
Photosensitive area (H × V)	1.9968 × 1.9968	mm
Package	Ceramic	-
Window material	Borosilicate glass	mm

▣ Absolute maximum ratings

Parameter	Symbol	Condition	Value	Unit
Analog supply voltage	Vdd(A)	Ta=25 °C	-0.3 to +6	V
Digital supply voltage	Vdd(D)	Ta=25 °C	-0.3 to +6	V
Gain selection terminal voltage	Vg	Ta=25 °C	-0.3 to +6	V
AD mode selection voltage	Vsel	Ta=25 °C	-0.3 to +6	V
Clock pulse voltage	V(clk)	Ta=25 °C	-0.3 to +6	V
Start pulse voltage	V(st)	Ta=25 °C	-0.3 to +6	V
Operating temperature	Topr	No dew condensation*1	-5 to +65	°C
Storage temperature	Tstg	No dew condensation*1	-10 to +85	°C
Soldering temperature*2	Tsol		240 (2 times)	°C

Note: Exceeding the absolute maximum ratings even momentarily may cause a drop in product quality. Always be sure to use the product within the absolute maximum ratings.

*1: When there is a temperature difference between a product and the surrounding area in high humidity environment, dew condensation may occur on the product surface. Dew condensation on the product may cause deterioration in characteristics and reliability.

*2: Reflow soldering, IPC/JEDEC J-STD-020 MSL 5, see P.9

▣ Recommended terminal voltage (Ta=25 °C)

Parameter	Symbol	Min.	Typ.	Max.	Unit
Analog supply voltage	Vdd(A)	4.75	5	5.25	V
Digital supply voltage*3	Vdd(D)	3	5	Vdd(A)	V
Gain selection terminal voltage	High gain	0	-	0.4	V
	Low gain	Vdd(A) - 0.25	Vdd(A)	Vdd(A) + 0.25	
AD mode selection voltage	10-bit mode	Vdd(A) - 0.25	Vdd(A)	Vdd(A) + 0.25	V
	8-bit mode	0	-	0.4	
Clock pulse voltage	High level	Vdd(D) - 0.25	Vdd(D)	Vdd(D) + 0.25	V
	Low level	0	-	0.4	
Start pulse voltage	High level	Vdd(D) - 0.25	Vdd(D)	Vdd(D) + 0.25	V
	Low level	0	-	0.4	

*3: When the latter-stage digital processing circuit is a 3.3 V family, the high level of digital output signal is 3.3 V when operated at Vdd(A)=5 V, Vdd(D)=3.3 V.

▣ Electrical characteristics (Ta=25 °C)

Parameter	Symbol	Min.	Typ.	Max.	Unit
Clock pulse frequency*4	10-bit MODE	500	-	5 M	Hz
	8-bit MODE	500	-	10 M	
Data rate	DR	-	f(clk)/12	-	Hz
Digital output voltage	High level	Vdd(D) - 0.15	-	-	V
	Low level	-	-	0.15	
Digital output rise time (10 to 90%)*5	CL=10 pF	-	-	30	ns
	CL=30 pF	-	-	60	
Digital output fall time (10 to 90%)*5	CL=10 pF	-	-	30	ns
	CL=30 pF	-	-	60	
Power consumption*6	P	-	75	-	mW

*4: Vdd(A)=Vdd(D)=5 V, V(clk)=V(st)=5 V, Vg=5 V (Low gain)

*5: CL: Load capacitance of digital output terminal

*6: Vdd(A)=Vdd(D)=5 V, V(clk)=V(st)=V(st)=5 V, f(clk)=5 MHz, f(st)=1.5 kHz

Electrical and optical characteristics [Ta=25 °C, Vdd(A)=Vdd(D)=5 V, V(clk)=V(st)=5 V]

Parameter	Symbol	Min.	Typ.	Max.	Unit
Spectral response range	λ		380 to 1000		nm
Peak sensitivity wavelength	λ_p	-	650	-	nm
Photosensitivity*7	High gain	-	40	-	V/nJ
	Low gain	-	8	-	
Dark current	I_D	-	0.2	0.6	pA
Saturation charge	Q_{sat}	-	8	-	pC
Feedback capacitance of charge amplifier*8	High gain	-	0.2	-	pF
	Low gain	-	1	-	
Dark output voltage*9	High gain	-	100	300	mV
	Low gain	-	20	60	
Saturation output voltage	High gain	2.5	3.5	-	V
	Low gain	2.5	3	-	
Photoresponse nonuniformity*10	PRNU	-	-	± 10	%

*7: $V_g=5$ V (Low gain), $V_g=0$ V (High gain)

*8: $\lambda=780$ nm

*9: Integration time=100 ms

*10: Photoresponse nonuniformity (PRNU) is the output nonuniformity that occurs when the entire photosensitive area is uniformly illuminated by light which is 50% of the saturation exposure level. PRNU is measured using 254 pixels excluding the pixels at both ends, and is defined as follows:

$$PRNU = \frac{\Delta X}{X} \times 100 (\%)$$

X: average output of all pixels, ΔX : difference between X and maximum or minimum output

Spectral response (typical example)

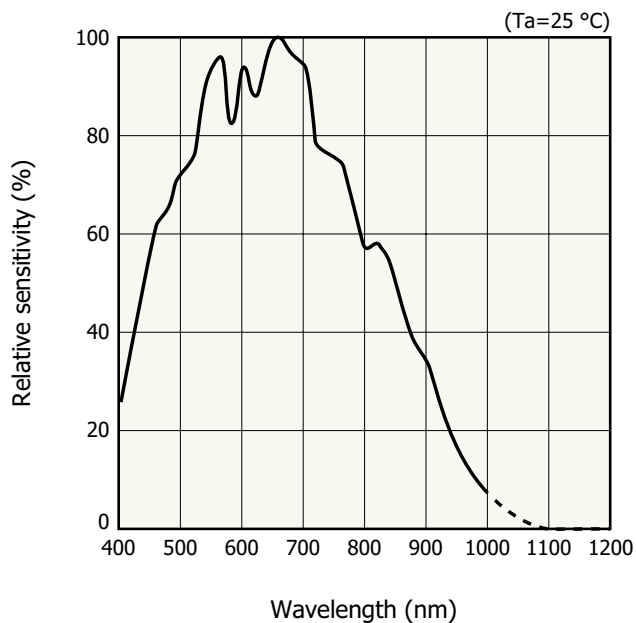

KMPDB0231EB

A/D converter characteristics (Ta=25 °C)

Parameter	Symbol	Value	Unit
Digital output format	-	Serial output	-
Resolution*11	10-bit mode	10	bit
	8-bit mode	8	
Conversion time	t_{CON}	$12/f(\text{clk})$	s/ch
Frame readout time	FR	$3100/f(\text{clk})$	s/f
Conversion voltage range*12	-	0 to 3.8	V

*11: $V_{sel}=5$ V (10-bit mode), $V_{sel}=0$ V (8-bit mode)

*12: Digital output is available from MSB as serial output.

10-bit mode: D9 to D0

8-bit mode: D7 to D0

Timing chart

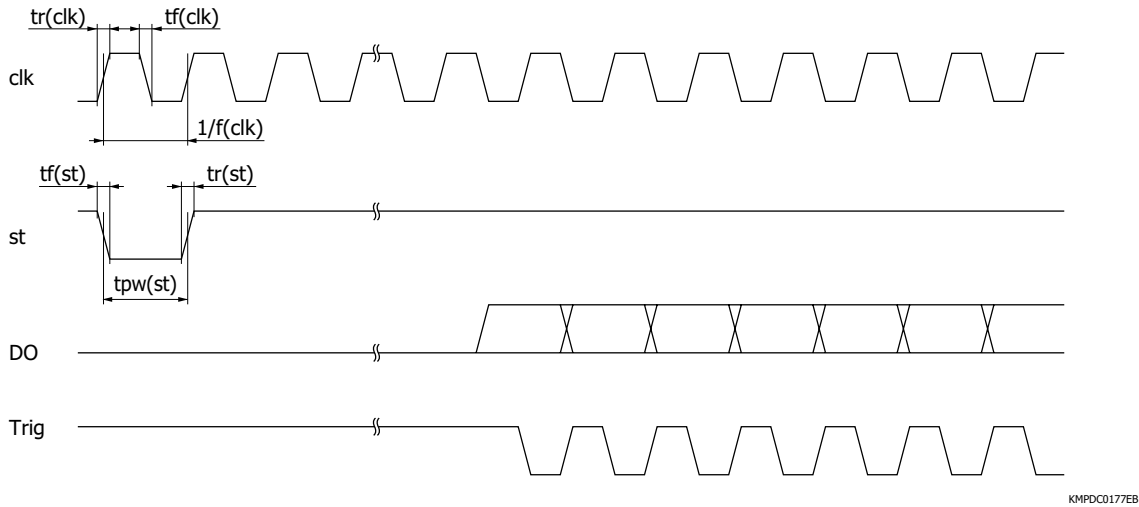

Parameter	Symbol	Min.	Typ.	Max.	Unit
Start pulse cycle	$T(st)$	$3101/f(clk)$	-	-	s
Clock pulse duty ratio	-	45	50	55	%
Clock pulse rise and fall times	$tr(clk), tf(clk)$	0	20	30	ns
Start pulse width	$tpw(st)$	90	-	-	ns
Start pulse rise and fall times	$tr(st), tr(st)$	0	20	30	ns

Note: Operation in the X and Y directions can be performed independently.

The internal timing circuit starts operating at the fall timing of the clock pulse immediately after the start pulse goes "Low".

It doesn't matter how many times the clock pulse goes "Low" during the "Low" period of the start pulse.

The integration time is determined by the start pulse cycles. However, since the charge storage of each pixel is carried out between the signal readout of that pixel and the next signal readout of the same pixel, the start time of charge integration differs depending on each pixel. In addition, the next start pulse cannot be input until signal readout from all pixels is completed.

The above timing chart applies to operation at 5 MHz. If operated at 10 MHz, the DO, Trig and EOC timings may delay by half a clock cycle.

8-bit mode

- In the neighborhood of start pixel

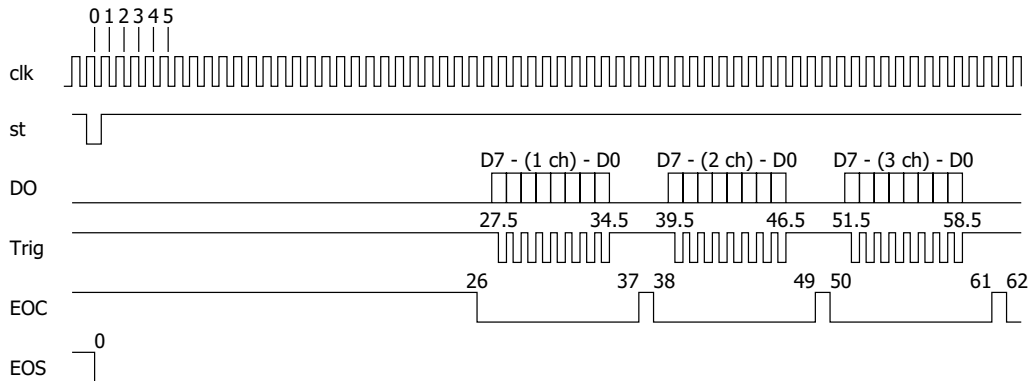

- In the neighborhood of last pixel

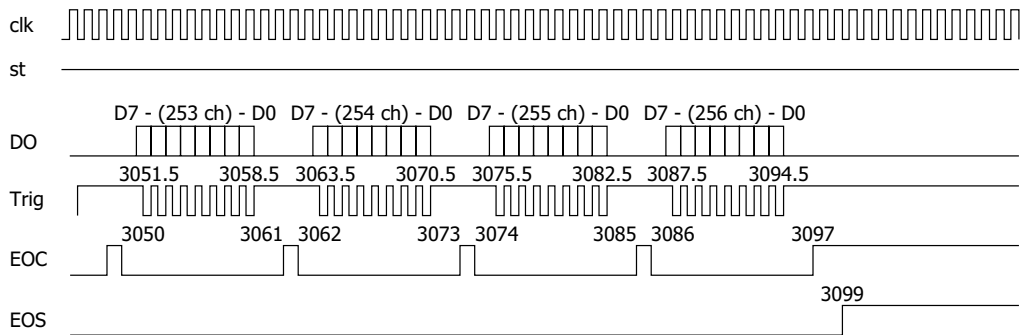

KMPDC0173EA

10-bit mode

- In the neighborhood of start pixel

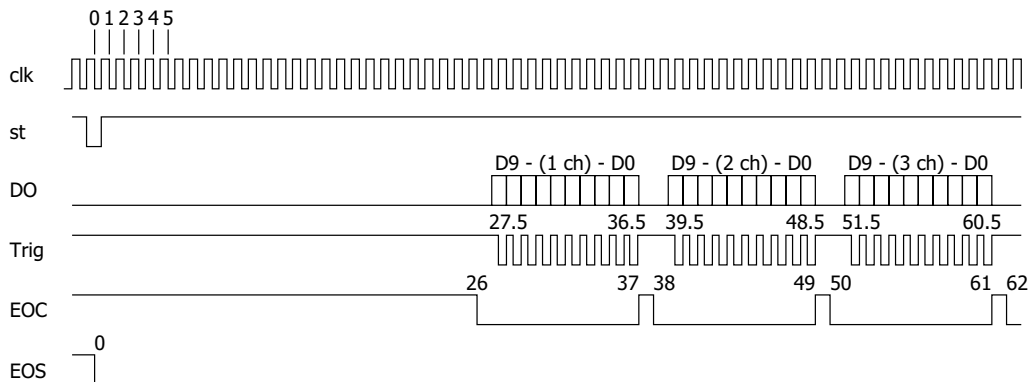

- In the neighborhood of last pixel

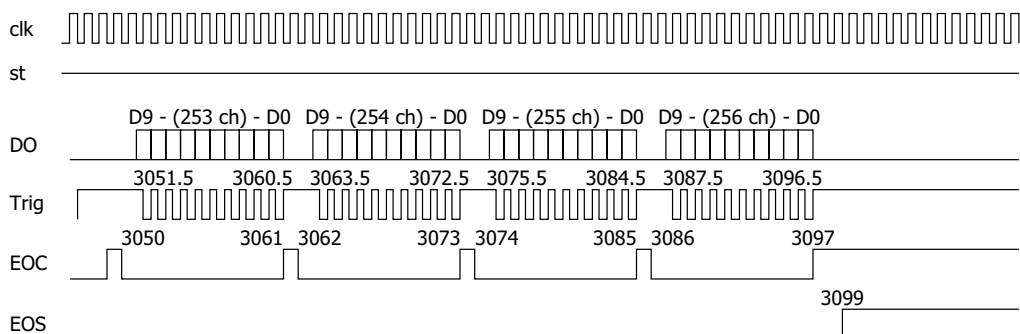

KMPDC0174EA

Block diagram

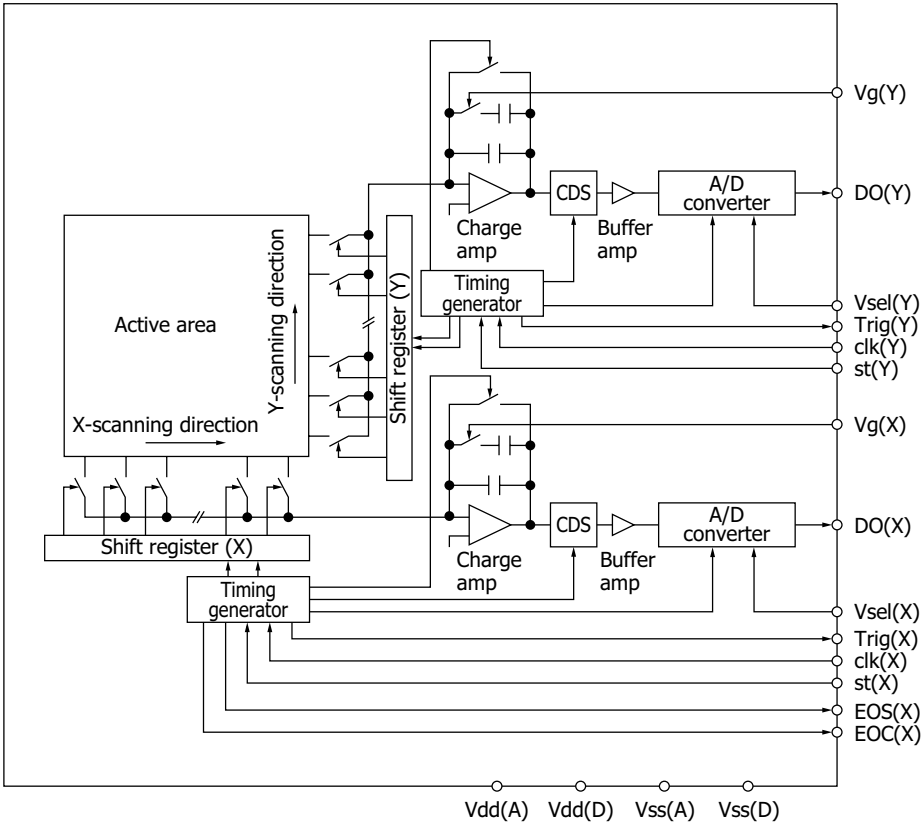

KMPDC0175EA

Connection examples

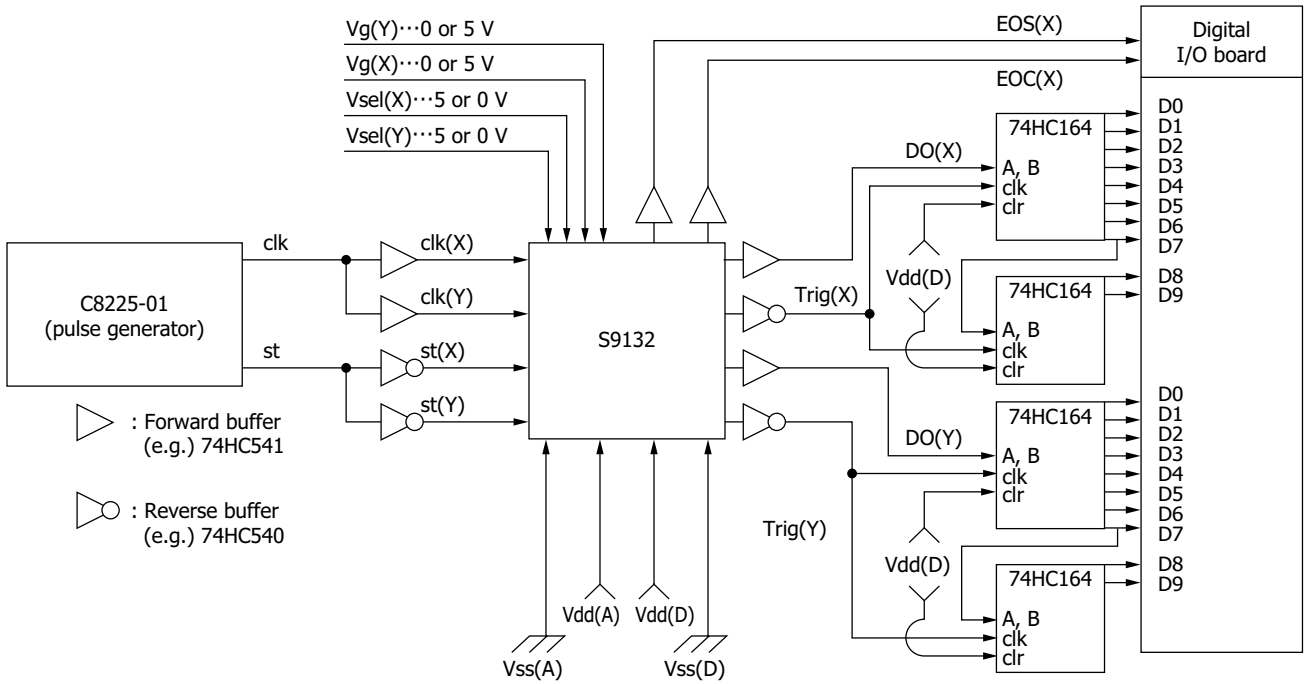

KMPDC0176EC

Dimensional outline (unit: mm)

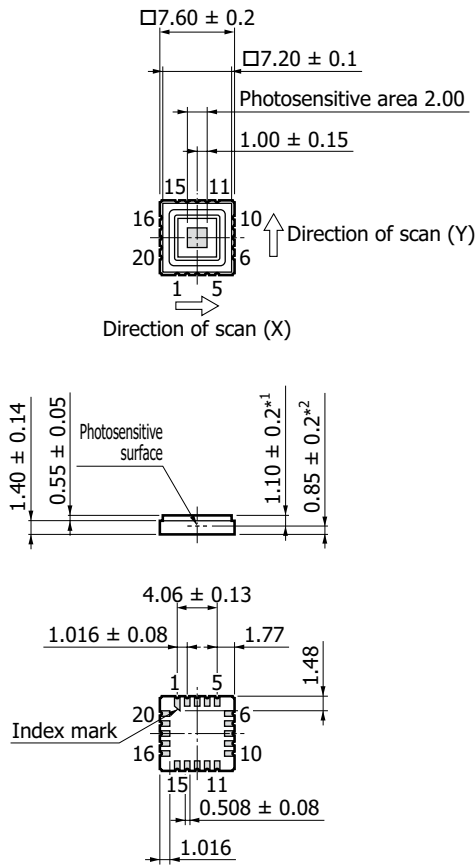

*1: Distance from upper surface of window to photosensitive surface
 *2: Distance from bottom surface of package to photosensitive surface

KMPDA0174EC

Pin no.	Symbol	I/O	Function
1	Vsel(X)	I	AD mode selection voltage
2	Vg(X)	I	Gain selection voltage
3	st(X)	I	Start pulse
4	clk(X)	I	Clock pulse
5	EOS(X)	O	End of scan pulse
6	clk(Y)	I	Clock pulse
7	st(Y)	I	Start pulse
8	Vdd(A)	I	Analog supply voltage
9	Vg(Y)	I	Gain selection voltage
10	Vsel(Y)	I	AD mode selection voltage
11	Vss(A)	I	Analog ground
12	Vss(D)	I	Digital ground
13	Trig(Y)	O	Trigger pulse
14	DO(Y)	O	Digital output
15	Vdd(D)	I	Digital supply voltage
16	NC		No connection
17	DO(X)	O	Digital output
18	Trig(X)	O	Trigger pulse
19	EOC(X)	O	End of conversion pulse
20	Vss(A)	I	Analog ground

Profile sensor mounted on terminal pitch conversion board S9132-01

S9132-01 is a profile sensor mounted on a terminal pitch conversion board having 1-inch (2.54 mm) pitch output terminals.

Dimensional outline (unit: mm)

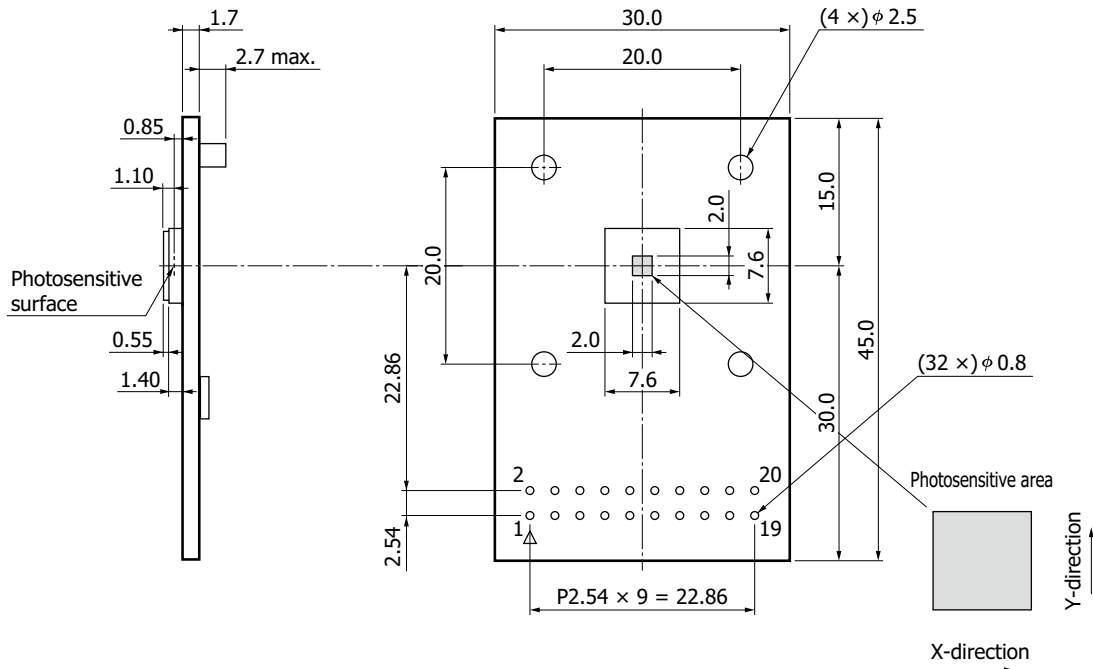

KMPDA0180EC

Pin no.	Symbol	I/O	Function
1	Vsel(X)	I	AD mode selection voltage
2	Vg(X)	I	Gain selection voltage
3	st(X)	I	Start pulse
4	clk(X)	I	Clock pulse
5	EOS(X)	O	End of scan pulse
6	clk(Y)	I	Clock pulse
7	st(Y)	I	Start pulse
8	Vdd(A)	I	Analog supply voltage
9	Vg(Y)	I	Gain selection voltage
10	Vsel(Y)	I	AD mode selection voltage
11	Vss(A)	I	Analog ground
12	Vss(D)	I	Digital ground
13	Trig(Y)	O	Trigger pulse
14	DO(Y)	O	Digital output
15	Vdd(D)	I	Digital supply voltage
16	NC		No connection
17	DO(X)	O	Digital output
18	Trig(X)	O	Trigger pulse
19	EOC(X)	O	End of conversion pulse
20	Vss(A)	I	Analog ground

Precautions

(1) Electrostatic countermeasures

This device has a built-in protection circuit against static electrical charges. However, to prevent destroying the device with electrostatic charges, take countermeasures such as grounding yourself, the workbench and tools to prevent static discharges. Also protect this device from surge voltages which might be caused by peripheral equipment.

(2) Incident window

If dust or dirt gets on the light incident window, it will show up as black blemishes on the image. When cleaning, avoid rubbing the window surface with dry cloth or dry cotton swab, since doing so may generate static electricity. Use soft cloth, paper or a cotton swab moistened with alcohol to wipe dust and dirt off the window surface. Then blow compressed air onto the window surface so that no spot or stain remains.

(3) Soldering by hand

To prevent damaging the device during soldering, take precautions to prevent excessive soldering temperatures and times. Soldering should be performed within 5 seconds at a soldering temperature below 260 °C.

(4) Reflow soldering

Soldering conditions may differ depending on the board size, reflow furnace, etc. Check the conditions before soldering. A sudden temperature rise and cooling may be the cause of trouble, so make sure that the temperature change is within 4 °C per second. The bonding portion between the ceramic base and the glass may discolor after reflow soldering, but this has no adverse effects on the hermetic sealing of the product.

(5) UV exposure

This product is not designed to prevent deterioration of characteristics caused by UV exposure, so do not expose it to UV light.

Recommended reflow soldering conditions (typical example)

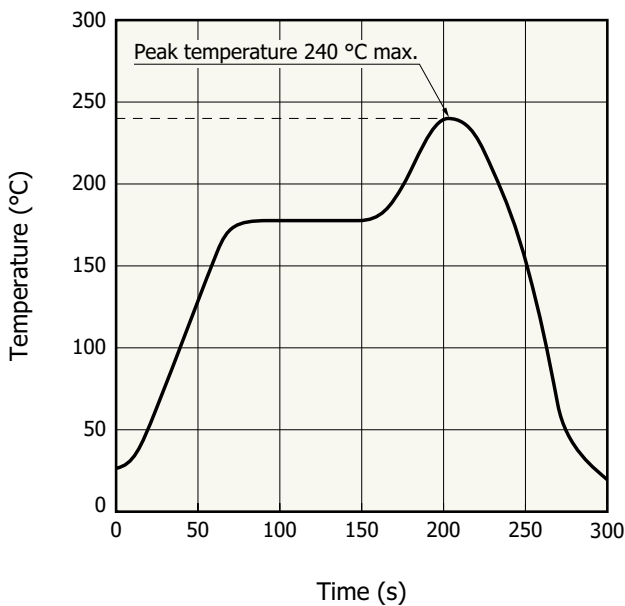

KAPDB0169EA

Related information

www.hamamatsu.com/sp/ssd/doc_en.html

■ Precautions

- Notice
- Image sensors/Precautions
- Surface mount type products/Precautions

Information described in this material is current as of December, 2022.

Product specifications are subject to change without prior notice due to improvements or other reasons. This document has been carefully prepared and the information contained is believed to be accurate. In rare cases, however, there may be inaccuracies such as text errors. Before using these products, always contact us for the delivery specification sheet to check the latest specifications.

The product warranty is valid for one year after delivery and is limited to product repair or replacement for defects discovered and reported to us within that one year period. However, even if within the warranty period we accept absolutely no liability for any loss caused by natural disasters or improper product use. Copying or reprinting the contents described in this material in whole or in part is prohibited without our prior permission.

HAMAMATSU

www.hamamatsu.com

HAMAMATSU PHOTONICS K.K., Solid State Division

1126-1 Ichino-cho, Higashi-ku, Hamamatsu City, 435-8558 Japan, Telephone: (81)53-434-3311, Fax: (81)53-434-5184

U.S.A.: HAMAMATSU CORPORATION: 360 Foothill Road, Bridgewater, NJ 08807, U.S.A., Telephone: (1)908-231-0960, Fax: (1)908-231-1218

Germany: HAMAMATSU PHOTONICS DEUTSCHLAND GMBH: Arzbergerstr. 10, 82211 Herrsching am Ammersee, Germany, Telephone: (49)8152-375-0, Fax: (49)8152-265-8 E-mail: info@hamamatsu.de

France: HAMAMATSU PHOTONICS FRANCE S.A.R.L.: 19 Rue du Saule Trapu, Parc du Moulin de Massy, 91882 Massy Cedex, France, Telephone: (33)1 69 53 71 00, Fax: (33)1 69 53 71 10 E-mail: infos@hamamatsu.fr

United Kingdom: HAMAMATSU PHOTONICS UK LIMITED: 2 Howard Court, 10 Tewin Road, Welwyn Garden City, Hertfordshire, AL7 1BW, UK, Telephone: (44)1707-294888, Fax: (44)1707-325777 E-mail: info@hamamatsu.co.uk

North Europe: HAMAMATSU PHOTONICS NORDEN AB: Torshamnsgatan 35, 16440 Kista, Sweden, Telephone: (46)8-509-031-00, Fax: (46)8-509-031-01 E-mail: info@hamamatsu.se

Italy: HAMAMATSU PHOTONICS ITALIA S.R.L.: Strada della Moia, 1 int. 6 20044 Arese (Milano), Italy, Telephone: (39)02-93 58 17 33, Fax: (39)02-93 58 17 41 E-mail: info@hamamatsu.it

China: HAMAMATSU PHOTONICS (CHINA) CO., LTD.: 1201, Tower B, Jianning Center, 27 Dongsanhuan Beilu, Chaoyang District, 100020 Beijing, P.R. China, Telephone: (86)10-6586-6006, Fax: (86)10-6586-2866 E-mail: hpc@hamamatsu.com.cn

Taiwan: HAMAMATSU PHOTONICS TAIWAN CO., LTD.: 8F-3, No.158, Section 2, Gongdao 5th Road, East District, Hsinchu, 300, Taiwan R.O.C. Telephone: (886)3-659-0080, Fax: (886)3-659-0081 E-mail: info@hamamatsu.com.tw